

**Henny Penny
Heated Holding Cabinet**

Model HHC-900

Model HHC-902

Model HHC-903

Model HHC-906

Model HHC-908

Model HC-15



TECHNICAL MANUAL



PLATONSERVICE

8 (800) 500-34-47

www.platonservice.com

TABLE OF CONTENTS

Section		Page
Section 1.	TROUBLESHOOTING.....	1-1
	1-1. Introduction.....	1-1
	1-2. Safety	1-1
	1-3. Troubleshooting	1-1
Section 2.	MAINTENANCE	2-1
	2-1. Introduction.....	2-1
	2-2. Test Instruments	2-1
	2-3. Removal of Module Access Panel	2-1
	2-4. Module Removal.....	2-1
	2-5. Removal of Module Housing	2-2
	2-6. Fuse	2-3
	2-7. Power Switch	2-4
	2-8. Thermostat	2-5
	2-9. Indicating Lights.....	2-6
	2-10. Thermometer.....	2-7
	2-11. Heater.....	2-8
	2-12. High Limit	2-9
	2-13. Blower	2-10
	2-14. Door Gasket Replacement.....	2-12
	2-15. Wiring Diagrams	2-13
Section 3.	PARTS INFORMATION.....	3-1
	3-1. Introduction.....	3-1
	3-2. Genuine Parts.....	3-1
	3-3. How to Find Parts	3-1
	3-4. How to Order	3-1
	3-5. Prices.....	3-2
	3-6. Delivery.....	3-2
	3-7. Warranty.....	3-2
	3-8. Recommended Spare Parts for Distributors.....	3-2



PLATONSERVICE

8 (800) 500-34-47

www.platonservice.com

SECTION 1. TROUBLESHOOTING

1-1. INTRODUCTION

This section provides troubleshooting information in the form of an easy to read list.

If a problem occurs during the first operation of a new cabinet, recheck the Installation Section of the Operator's Manual.

Before troubleshooting, always recheck the Operation Section of the Operator's Manual.

1-2. SAFETY

Where information is of particular importance or is safety related, the words NOTICE, CAUTION, or WARNING are used. Their usage is described below.



SAFETY ALERT SYMBOL is used with DANGER, WARNING, or CAUTION which indicates a personal injury type hazard.



NOTICE is used to highlight especially important information.



CAUTION used without the safety alert symbol indicates a potentially hazardous situation which, if not avoided, may result in property damage.



CAUTION used with the safety alert symbol indicates a potentially hazardous situation which, if not avoided, may result in minor or moderate injury.



The word WARNING is used to alert you to a procedure, that if not performed properly, might cause personal injury.

1-3. TROUBLESHOOTING

To isolate a malfunction proceed as follows:

1. Clearly define the problem or symptom and when it occurs.
2. Locate the problem in the troubleshooting table.
3. Review all possible causes, then one at a time work through the list of corrections until the problem is solved.



If maintenance procedures are not followed correctly, injuries and/or property damage could result.

1-3. TROUBLESHOOTING (Continued)

PROBLEM	CAUSE	CORRECTION
OPERATION		
<p>A. Product not holding temperature</p>	<ul style="list-style-type: none"> • Doors are left open • Thermostat set too low • Gasket torn or worn • Heater not working • Blower not working • Product held too long • Low or improper voltage 	<ul style="list-style-type: none"> • Keep doors closed except to load and unload product • Increase thermostat setting by moving the knob to a higher number setting • Replace gasket per Door Gasket Replacement Section • Check heater; replace per Heater Section • Check blower; replace per Blower Section • Hold product only for recommended time • Using meter, compare receptacle voltage to data plate voltage
<p>B. Cabinet steaming - product becoming soggy</p>	<ul style="list-style-type: none"> • Too much humidity inside the cabinet • Holding product too long • Vent not set properly (units with vent adjustment only) 	<ul style="list-style-type: none"> • Empty water from the water pan • Hold product for recommended time • Adjust vent per Operator's Manual
<p>C. Product dry</p>	<ul style="list-style-type: none"> • No water in pan 	<ul style="list-style-type: none"> • Remove pan and put in approximately 1" of hot water
HEATING SYSTEM		
<p>A. Unit will not heat</p>	<ul style="list-style-type: none"> • Faulty thermostat • Faulty high limit • Faulty heater • Faulty wiring 	<ul style="list-style-type: none"> • Check thermostat per Thermostat Section • Check high limit per High Limit Section • Check heater; replace per Heater Section • Check wiring for loose connections or broken wires and repair as needed

1-3. TROUBLESHOOTING (Continued)

PROBLEM	CAUSE	CORRECTION
HEATING SYSTEM (Continued)		
<p>B. Unit will not heat to desired temperature</p>	<ul style="list-style-type: none"> • Faulty blower • Thermometer not indicating true temperature • One of heaters defective • Doors being left open too much • Gaskets torn or worn • Defective high limit on one of heaters 	<ul style="list-style-type: none"> • Check blower; replace per Blower Section • Check cabinet temperature with another thermometer; if necessary, replace per Thermometer Section • Check heater; replace per Heater Section • Only open doors as necessary • Replace gasket per Door Gasket Replacement Section • Check high limit; replace per High Limit Section
<p>C. Unit overheating</p>	<ul style="list-style-type: none"> • Faulty thermostat • Faulty blower 	<ul style="list-style-type: none"> • Check thermostat; replace per Thermostat Section • Check blowers; replace per Blower Section
VENTILATING SYSTEM		
<p>A. Both blowers not working</p>	<ul style="list-style-type: none"> • Faulty blowers • Faulty fuse (if equipped) 	<ul style="list-style-type: none"> • Check blowers; replace per Blower Section • Check fuse; replace per Fuse Section



PLATONSERVICE

8 (800) 500-34-47

www.platonservice.com

SECTION 2. MAINTENANCE

2-1. INTRODUCTION

This section provides procedures for the testing and replacement of the various parts used within the cabinet. Before replacing any parts, refer to the Troubleshooting Section. It will aid you in determining the cause of the malfunction.

2-2. TEST INSTRUMENTS

You may use two test instruments to check the electric components.

1. A continuity light
2. An ohmmeter

When the manual refers to the circuit being closed, the continuity light illuminates or the ohmmeter reads zero unless otherwise noted. When the manual refers to the circuit being open, the continuity light will not illuminate or the ohmmeter will read 1 (one) or infinite resistance.

A continuity tester cannot be used to check coils.

2-3. REMOVAL OF THE MODULE ACCESS PANEL

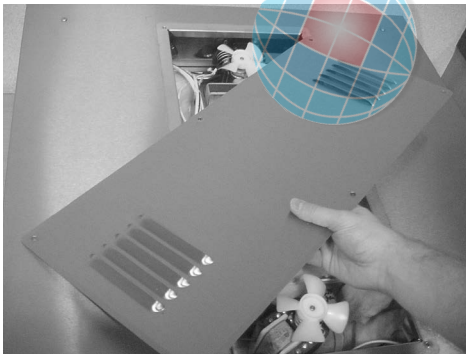

In most procedures of the maintenance section, the access panel must be removed from the top of the module. This access panel can easily be removed by taking out the four screws that fasten it to the module shell.

2-4. MODULE REMOVAL



NOTICE

If the component module of the cabinet has to be removed, be sure to remove the four screws (one at each corner) before lifting it from the unit. Also, when work has been completed on the module, be sure to relocate it properly and reinstall the screws that fasten the module to the cabinet. Failure to do so might cause the unit to perform inadequately.

2-5. REMOVAL OF MODULE HOUSING

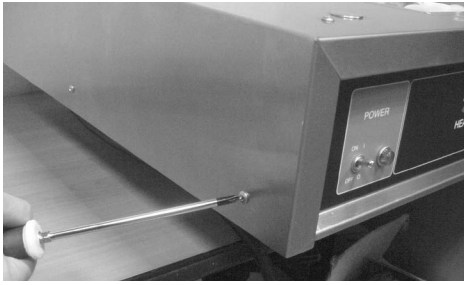

Step 2

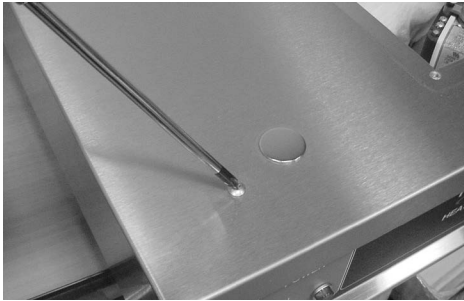

Step 3

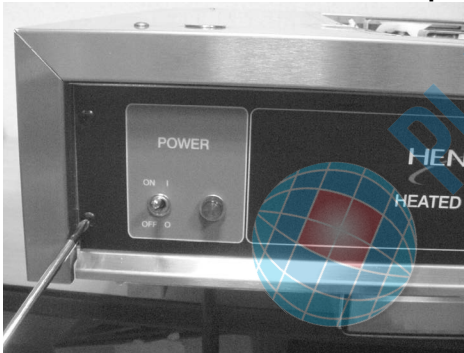

Step 4

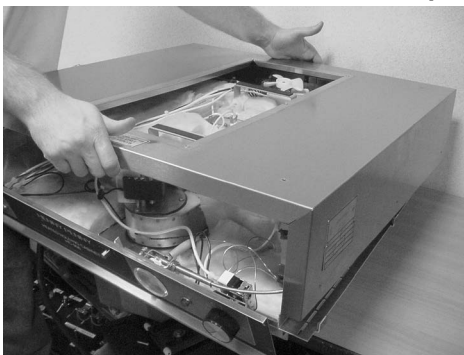

Step 5

If the need for extensive service is required on the module components, the entire outer shell of the module can be removed to make servicing easier. To remove the outer shell of the module, follow these procedures:

1. Remove the module from the cabinet per Module Removal Section.
2. Remove the six (6) screws that are located on the sides of the module.
3. Remove the four (4) screws located at the corners of the module top.
4. Remove the screws from the control panel and the back panel, that fasten them to the module housing.
5. Lift the shell of the module off the unit.
6. When work is completed, reassemble in reverse order.

2-6. FUSE



Step 2



Step 3

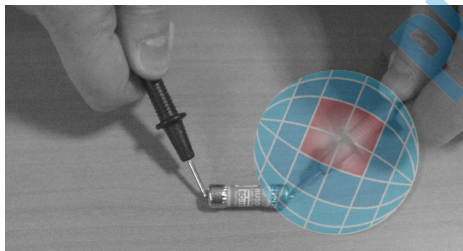

Step 4

NOTICE

All units are not equipped with fuses.

If both blowers quit working at the same time:

1. Remove electrical power supplied to the cabinet.



To avoid electrical shock or property damage, move the power switch to OFF and disconnect main circuit breaker, or unplug cord at wall receptacle.

2. Remove the cap from the fuse holder by turning it counter-clockwise. (Located above the power cord.)
3. Pull the fuse from the holder.
4. Check the fuse for defectiveness by putting both leads of the ohmmeter or continuity light on opposite ends of the fuse. The fuse should be closed, or read no resistance. If the fuse is found to be defective, replace it with a new one. Be sure to use an identical fuse as the one being replaced.
5. Replace the cap to the fuse holder.
6. Reconnect the electrical supply to the cabinet.

2-7. POWER SWITCH

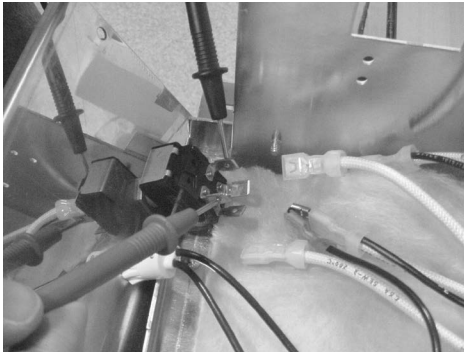

Step 3

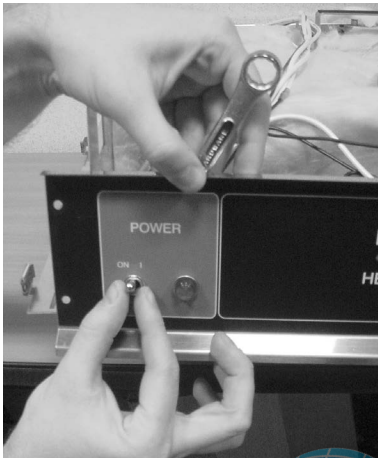

To avoid electrical shock or property damage, move the power switch to OFF and disconnect main circuit breaker, or unplug cord at wall receptacle.

1. Disconnect the electrical supply to the cabinet.
2. Remove the four (4) screws from the control panel and pull it down.
3. Remove all wires from the switch. Check across the two terminals of the switch for continuity. With the switch in the ON position, the circuit should be closed. With the switch in the OFF position, the circuit should be open. If the switch is found to be defective, replace it by continuing with the following instructions in this section.
4. Loosen the nut holding the switch on the back side of the control panel and then remove the nut on the front of the control panel.
5. Remove the switch.
6. Install a new switch in reverse order.
7. Reconnect the wires to the switch on the same terminals that they were previously on.
8. Push the control panel back in place and put in screws.
9. Reconnect the electrical supply to the cabinet.

2-8. THERMOSTAT

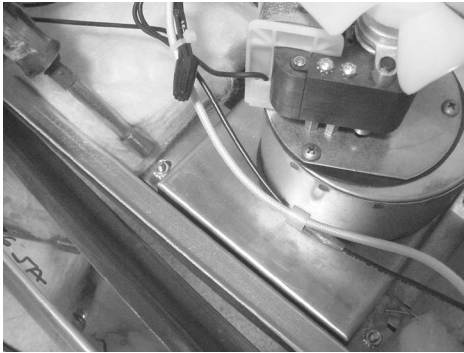

Step 5

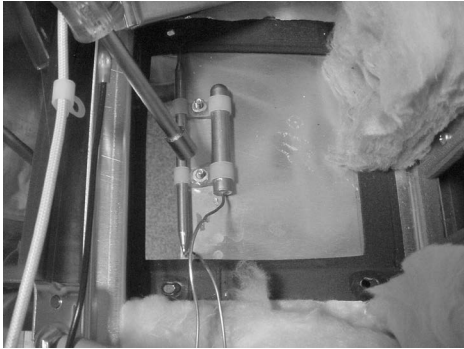

Step 7

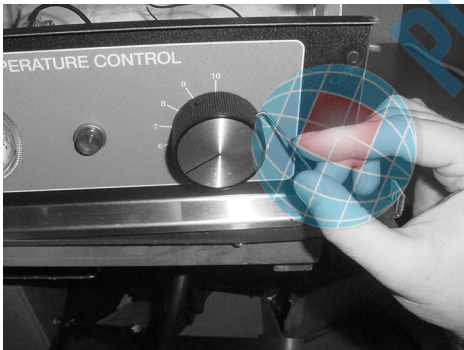

Step 8

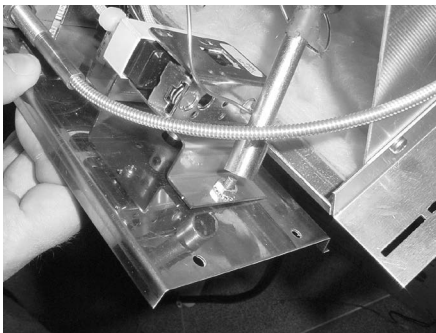

Step 11

1. Disconnect the electrical supply to the cabinet.



To avoid electrical shock or property damage, move the power switch to OFF and disconnect main circuit breaker, or unplug cord at wall receptacle.

2. Remove the access panel from the top of the module.
3. Remove the four (4) screws from the control panel and pull it down.
4. Remove the wires from the thermostat. With the thermostat set at the maximum setting (all the way clockwise), the circuit should be closed. With the thermostat in the 0, or OFF, position (all the way counterclockwise), the circuit should be open. If the thermostat is found to be defective, replace it by continuing with the following instructions in this section.
5. Remove the four (4) nuts that hold the blower box to the cabinet.
6. Lift the blower box up to expose the thermometer and thermostat bulbs.
7. While holding the blower box, remove the two (2) nuts that secure the bulb retaining clamps and remove the thermostat bulb from the clamps.
8. Using a 5/64" Allen wrench, loosen the two (2) set screws in the thermostat knob and remove the knob.
9. Remove the two (2) nuts that hold the thermostat bracket to the control panel.
10. Remove the thermostat shaft extension with a 1/16" Allen wrench.
11. Remove the two (2) screws that hold the thermostat to the bracket.
12. Remove the thermostat from the unit.

2-8. THERMOSTAT
(Continued)

13. Install a new thermostat in reverse order.
14. Reposition the blower box and secure it with the four (4) nuts previously removed.

CAUTION

Be sure that both the thermometer and thermostat capillary tubes pass through the notches in the front corners of the blower box. Failure to do so could permanently damage the thermometer or thermostat and cause improper operation of the cabinet.

15. Reseal the notches in the blower box corners with silicone rubber sealant.
16. Push the control panel back in place and put in screws.
17. Replace the access panel to the module.
18. Reconnect the electrical supply to the cabinet.

2-9. INDICATING LIGHTS



NOTICE

This section should be followed when replacing either of the two (2) indicating lights in the control panel.

1. Disconnect the electrical supply to the cabinet.



To avoid electrical shock or property damage, move the power switch to OFF and disconnect main circuit breaker, or unplug cord at wall receptacle.

2. Remove the four (4) screws from the control panel and pull it down.
3. Cut the light wires just behind the body of the light.

2-9. INDICATING LIGHTS
(Continued)



Step 4

4. Remove the light by squeezing the retainers on the body and pushing the light out through the control panel.
5. Install a new light by pushing it through the front of the control panel until it snaps securely in place.
6. Strip the ends of the cut wires and connect them to the new light with wire nuts.
7. Push the control panel back in place and put in screws.
8. Reconnect the electrical supply to the cabinet.

2-10. THERMOMETER



Step 4



To avoid electrical shock or property damage, move the power switch to OFF and disconnect main circuit breaker, or unplug cord at wall receptacle.

1. Disconnect the electrical supply to the cabinet.

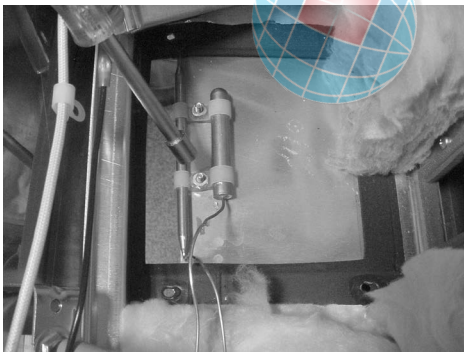

Step 6

2. Remove the access panel from the top of the module.
3. Remove the four (4) screws from the control panel and pull it down.
4. Remove the four (4) nuts that hold the blower box to the cabinet.
5. Lift the blower box up to expose thermometer and thermostat bulbs.
6. While holding the blower box, remove the two nuts that secure the bulb retaining clamps and remove the thermometer bulb from the clamps.



Step 7

7. Remove the two (2) nuts that hold the mounting brackets on the back of the thermometer body.
8. Remove the thermometer by pulling the body and capillary tube through the control panel.
9. Install a new thermometer in reverse order.
10. Reposition the blower box and secure it with the four (4) nuts previously removed.

2-10. THERMOMETER
(Continued)



Step 8

CAUTION

Be sure that both the thermometer and thermostat capillary tubes pass through the notches in the front corners of the blower box. Failure to do so could permanently damage the thermometer or thermostat and cause improper operation of the cabinet.

11. Reseal the notches in the blower box corners with silicone rubber sealant.
12. Replace the access panel to the top of the module.
13. Push the control panel back in place and put in screws.
14. Reconnect the electrical supply to the cabinet.

2-11. HEATER

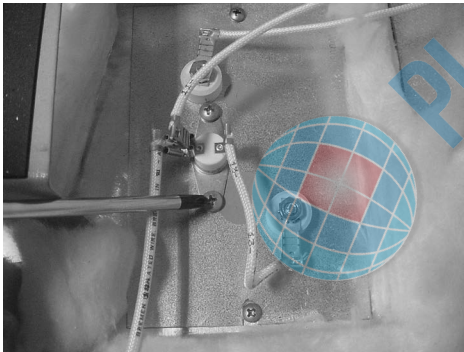

Step 3

NOTICE

This section should be followed when replacing either of the two (2) heaters in the cabinet. If there is a heating problem, both heaters should be checked.

1. Disconnect the electrical supply to the cabinet.



To avoid electrical shock or property damage, move the power switch to OFF and disconnect main circuit breaker, or unplug cord at wall receptacle.



Step 5

2. Remove the access panel from the top of the cabinet.
3. Remove the two (2) screws holding the high limit to the heater.
4. Remove the wires attached to the two (2) heater terminals.
5. Remove the two (2) screws holding the heater to the module.

2-11. HEATER
(Continued)



Step 6

6. Remove the heater.
7. Install a new heater in reverse order.

NOTICE

If you have a 240V, 3,000 W unit, you must install the new heater so that the coils are spread furthest apart where air from the blower enters the heater.

8. Reattach the heater wires.
9. Refasten the high limit to the new heater.
10. Replace the access panel to the module.
11. Reconnect the electrical supply to the cabinet.

2-12. HIGH LIMIT

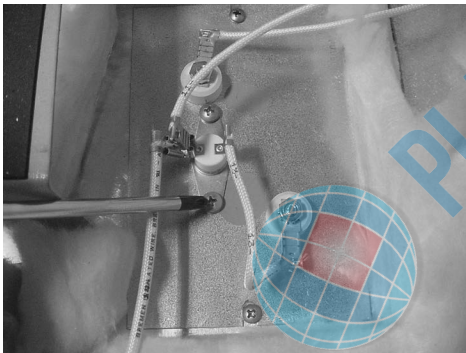

Step 5

1. Disconnect the electrical supply to the cabinet.

NOTICE

This section should be followed when replacing either of the two (2) high limits in the cabinet. If there is a heating problem in the cabinet, both high limits should be tested.



To avoid electrical shock, move the power switch to OFF and disconnect main circuit breaker, or unplug cord at wall receptacle.

2. Remove the access panel from the top of the cabinet.
3. Remove the wires attached to the high limit.
4. Check across high limit terminals for continuity. As long as cabinet temperature is below 210°F and blower has been operating properly, high limit should be closed, or read no resistance. If high limit is found to be defective, replace it by continuing with the following instructions.
5. Remove two (2) screws that hold high limit to the heater.

2-12. HIGH LIMIT
(Continued)

6. Remove the high limit.
7. Install a new high limit in reverse order.
8. Reconnect the two wires to the high limit.
9. Replace the access panel to the module.
10. Reconnect the electrical supply to the cabinet.

2-13. BLOWER

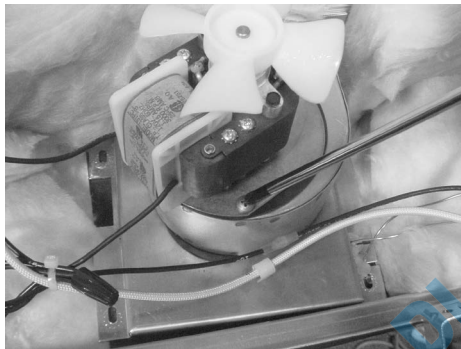

Step 3

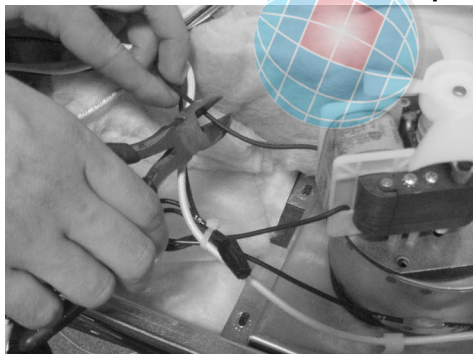

Step 4

NOTICE

Procedures for blower motor replacement are the same on both blowers.

1. Disconnect the electrical supply to the cabinet.



To avoid electrical shock or property damage, move the power switch to OFF and disconnect main circuit breaker, or unplug cord at wall receptacle.

2. Remove the access panel from the top of the cabinet.
3. Remove the three (3) screws that fasten the blower motor to the blower housing.
4. Cut the two (2) blower wires approximately 2" away from the blower.
5. Lift the blower motor and wheel out of the blower housing.
6. If replacing motor, fan, and wheel as an assembly, install new assembly in reverse order. If replacing just the motor, continue onto step 7.

2-13. BLOWER
(Continued)

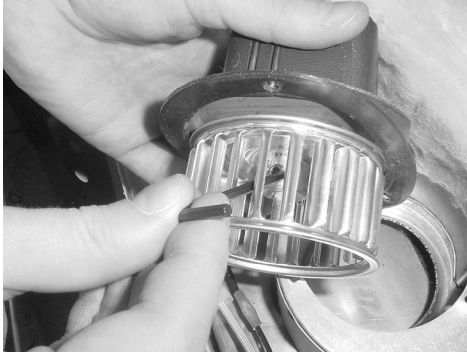

Step 7

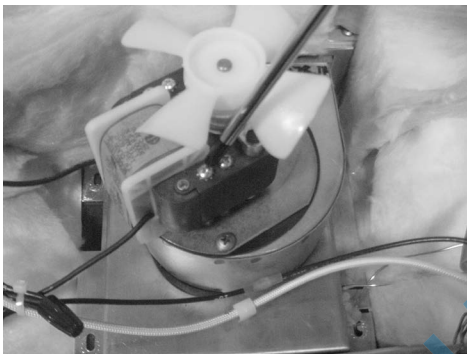

Step 8

NOTICE

The blower motor can be ordered as an assembly. This will include the motor, the fan, and the wheel. Normally, just the motor would need replacing if found to be defective. If you are just replacing the motor, continue with the following procedures.

7. The fan can be pulled off the shaft of the motor.
8. With a 5/64" Allen wrench, loosen the set screw that holds the blower wheel to the motor shaft and remove the wheel.
9. Remove the four (4) screws that hold the blower cover to the motor.
10. Install a new blower motor in reverse order.
11. Be sure to put the spacers back between the blower cover and the motor.

NOTICE

When replacing a blower motor, be sure that the motor coil is positioned away from the heater when reinstalling.

12. Reconnect the two wires to the new blower by stripping the wire ends and fastening with wire nuts.
13. Replace the access panel to the module.
14. Reconnect the electrical supply to the cabinet.



2-14. DOOR GASKET
REPLACEMENT



Steps 1 & 2

1. Pull the gasket to the side to expose the screws that hold the retainer to the cabinet.
2. Loosen the screws around the full outside perimeter of the gasket.
3. With the screws loose, the gasket should slide out from under the retainer.
4. Remove the gasket and replace with a new one by reversing the above procedures.



PLATON SERVICE

8 (800) 500-34-47

www.platonservice.com

2-15. WIRING DIAGRAMS

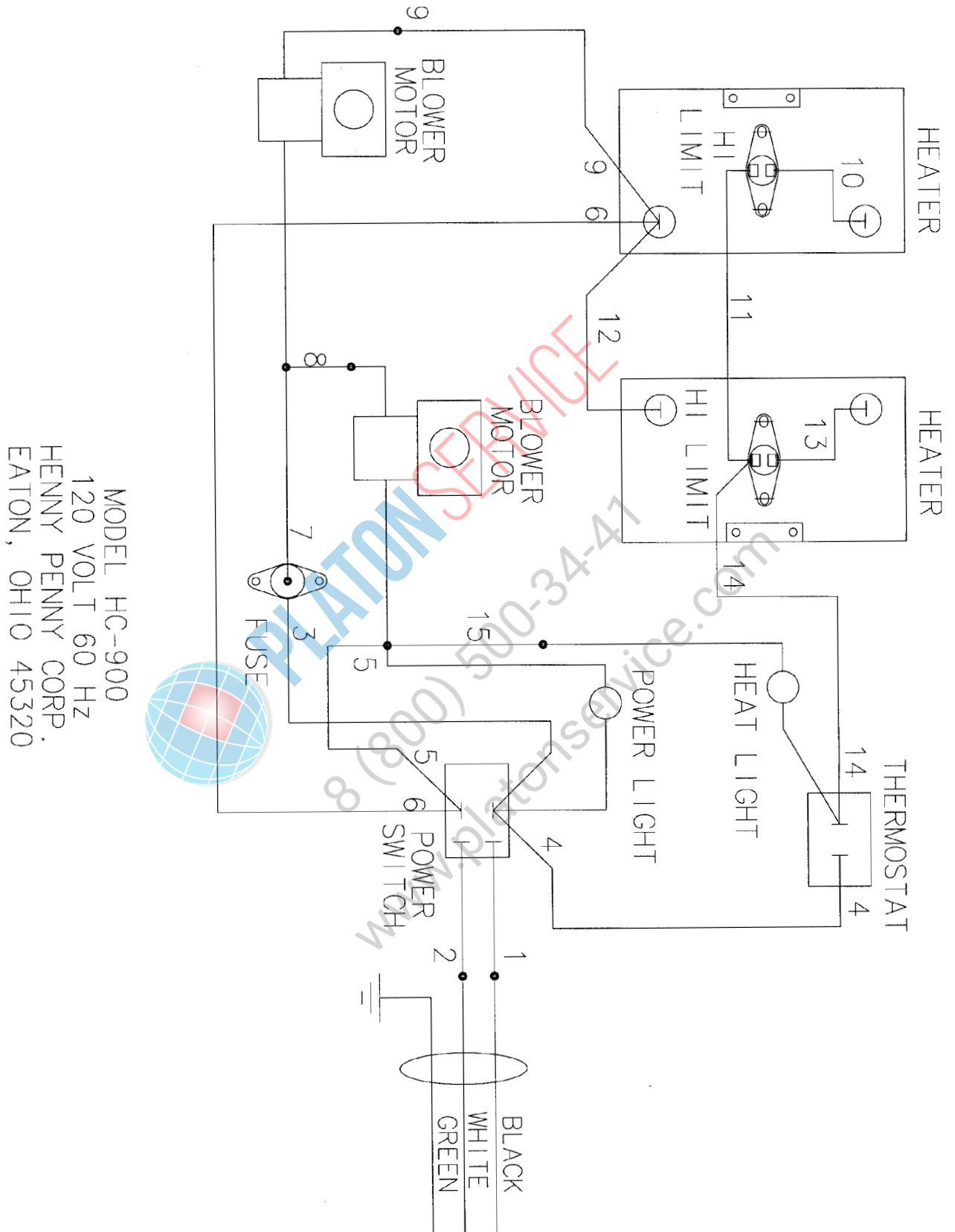

MODEL HC-900
120 VOLT 60 HZ
HENNY PENNY CORP.
EATON, OHIO 45320

C25894

2-15. WIRING DIAGRAMS (Continued)

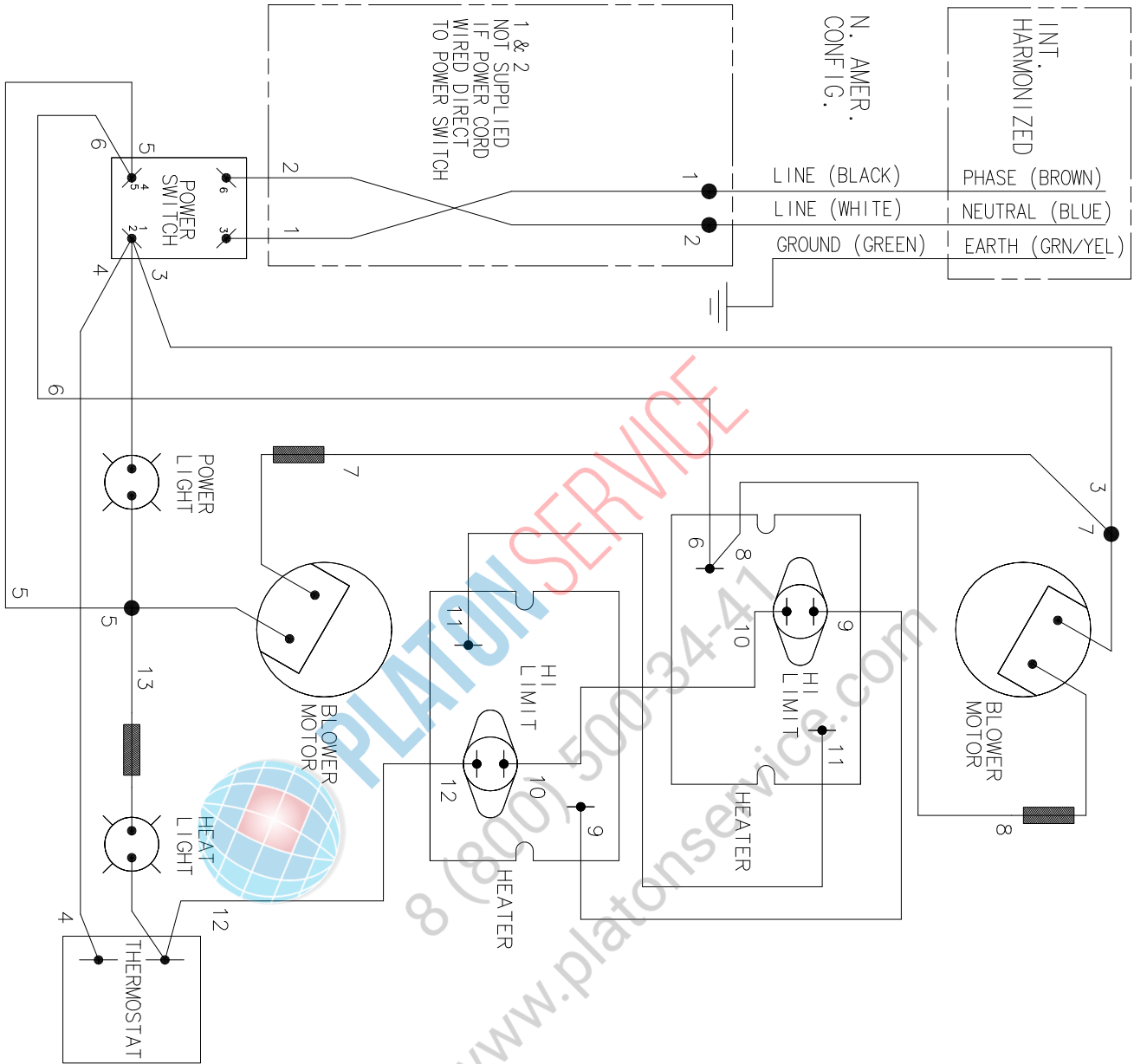

HC-900, HC-902
HC-903, HC-908
208-240V 50/60 HZ
1586W, 2086W
HENNY PENNY CORP.
EATON, OHIO 45320

27240

2-15. WIRING DIAGRAMS (Continued)

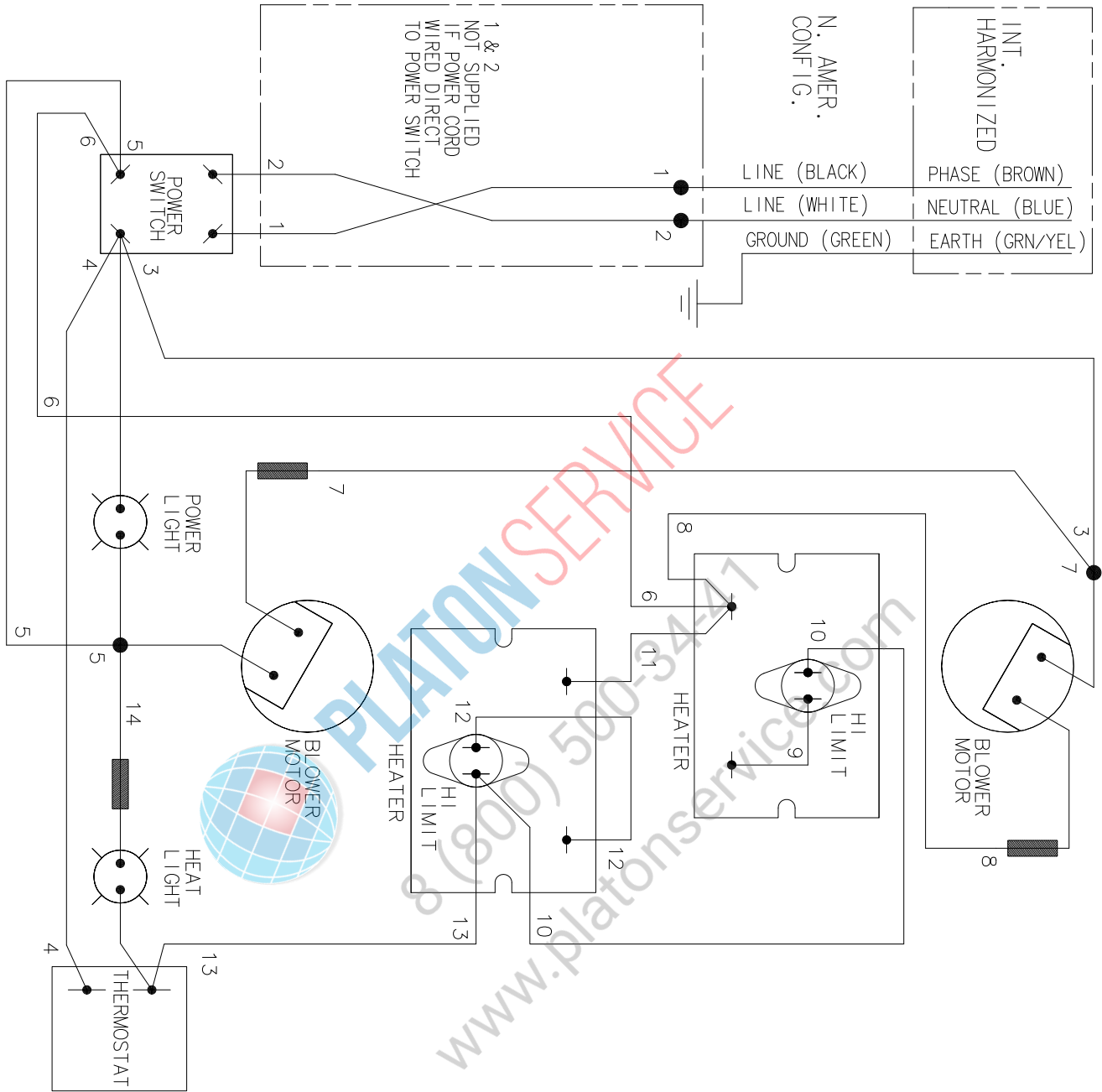

HC-900, HC-906
240V 50/60 HZ
3000W, 3086W
HENNY PENNY CORP.
EATON, OHIO 45320

27242

2-15. WIRING DIAGRAMS (Continued)

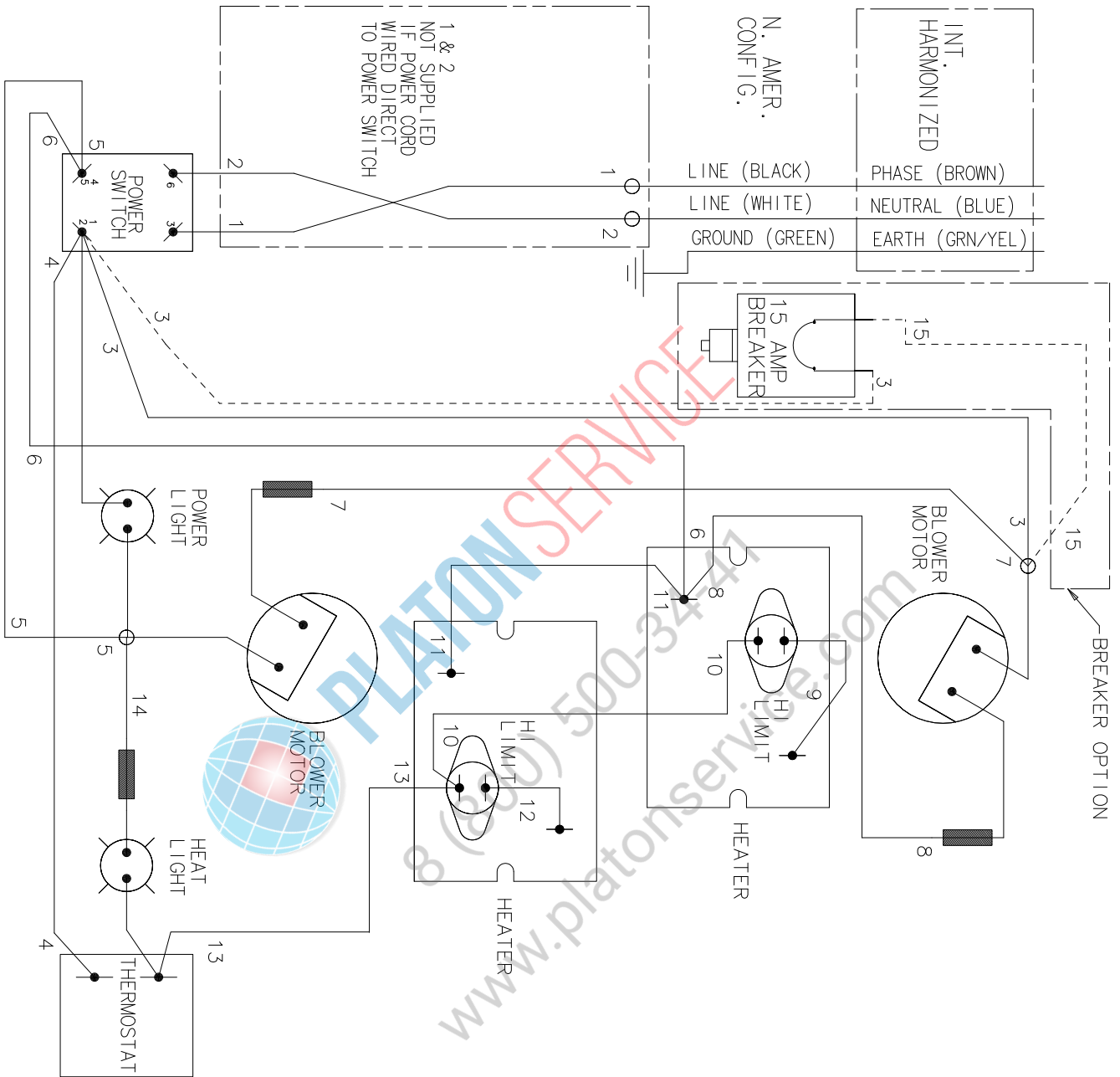

HC-900,
HC-902, HC-903
HC-906, HC-908
100/120V, 50/60 HZ
1450W, 1586W
HENNY PENNY CORP.
EATON, OHIO 45320

25974

2-15. WIRING DIAGRAMS (Continued)

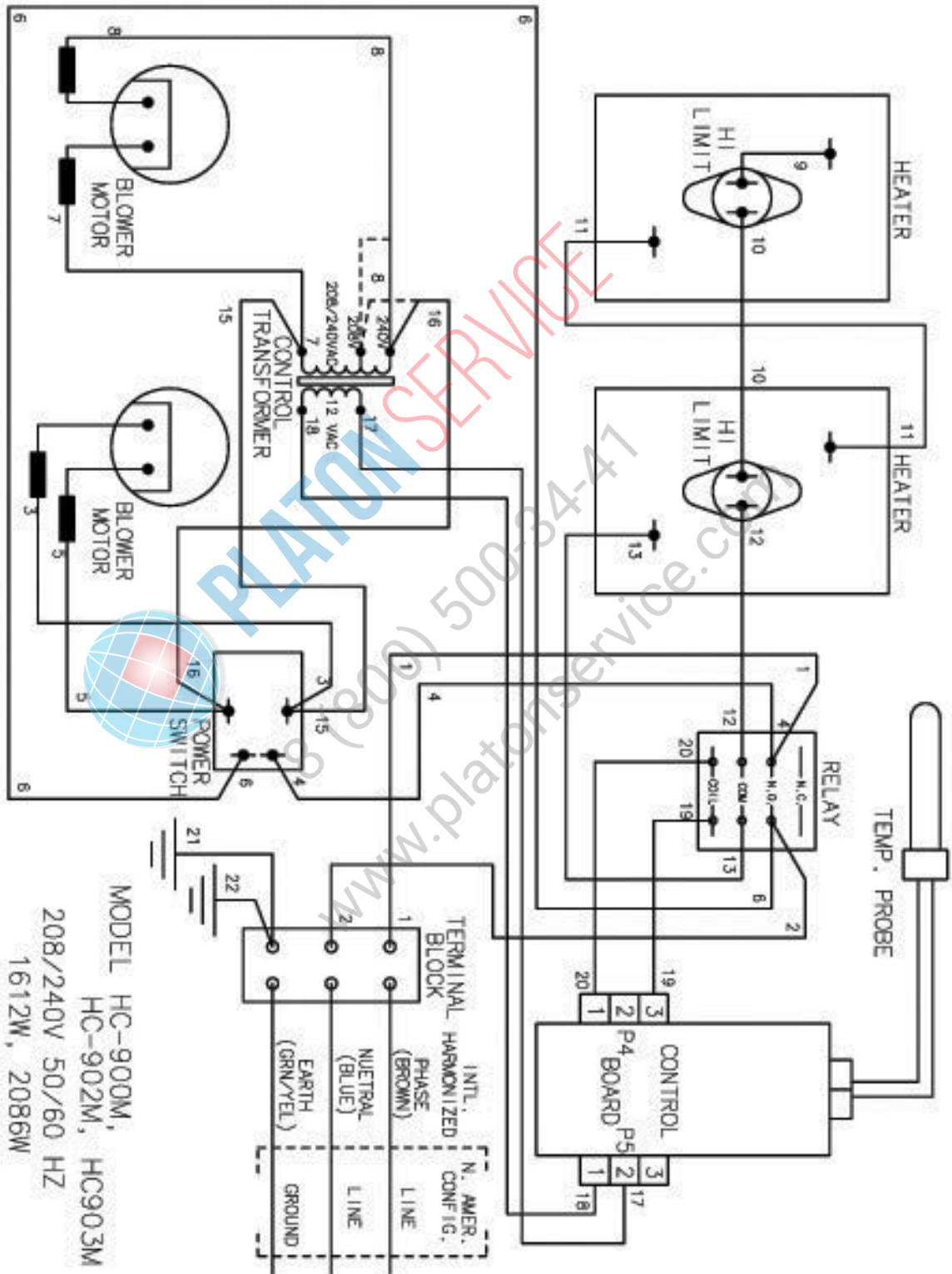

2-15. WIRING DIAGRAMS (Continued)

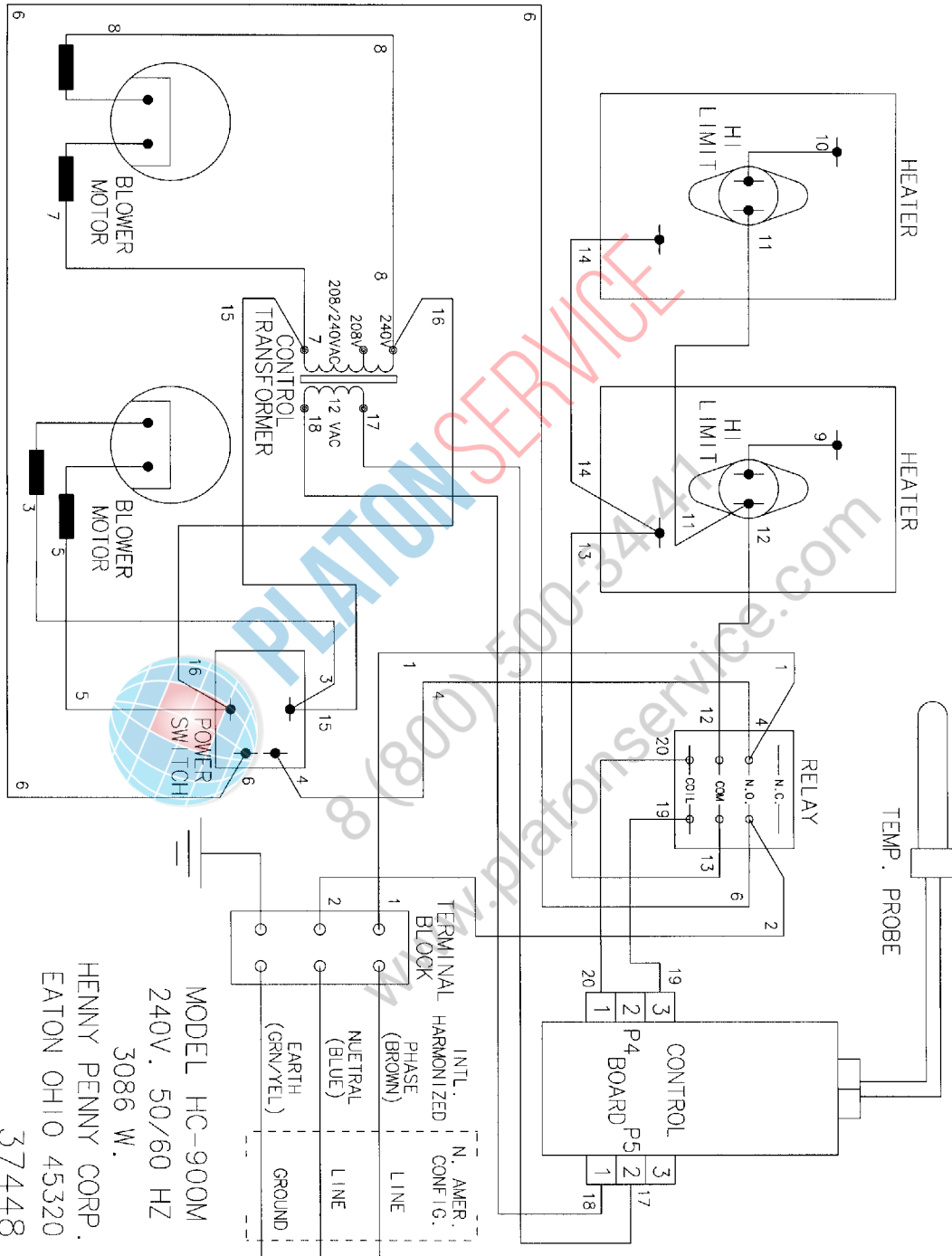

2-15. WIRING DIAGRAMS (Continued)

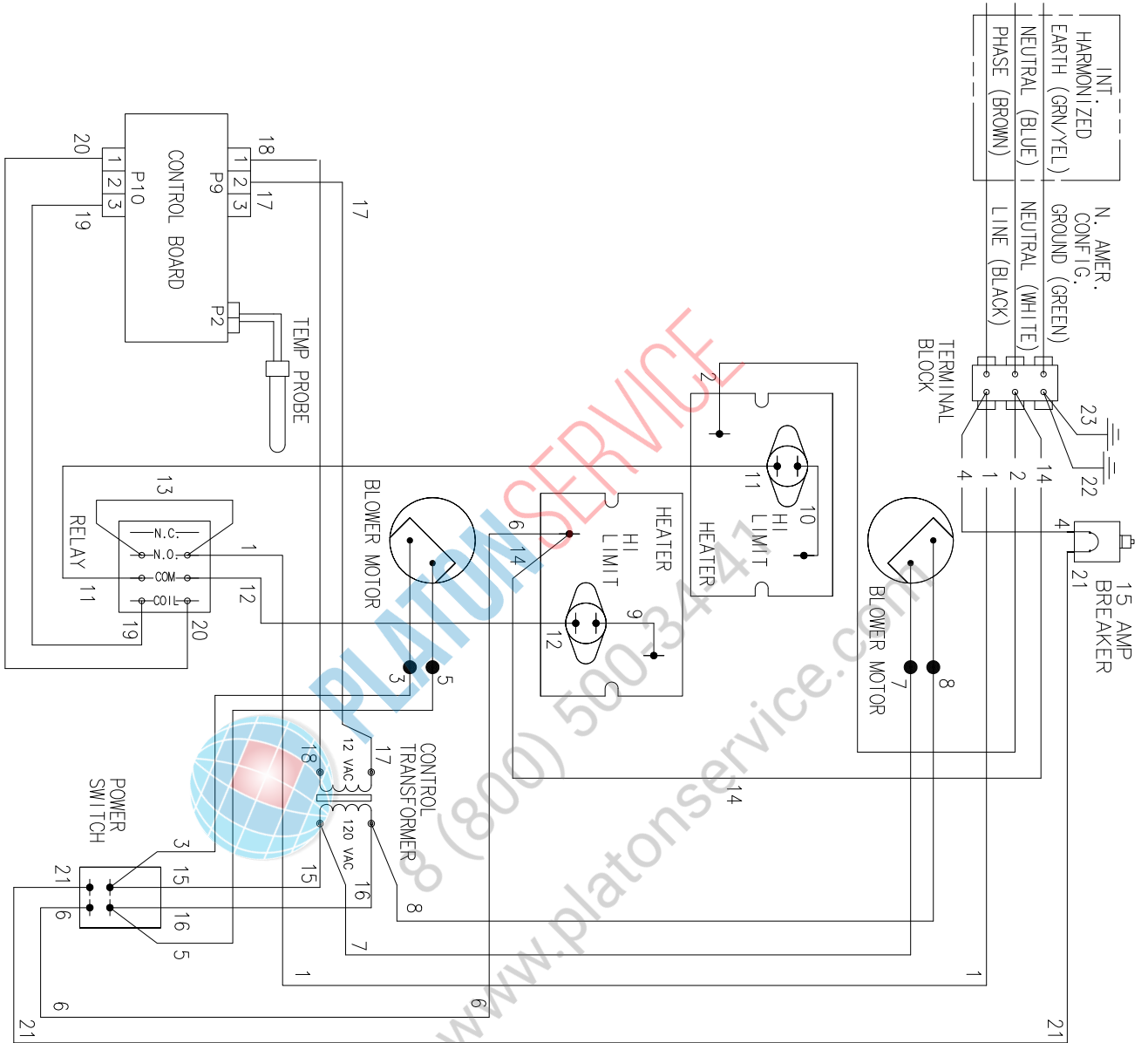

MODEL HC-900M
 HC-902M
 HC-903M
 100/120V., 50/60 HZ
 1450/1612/2086W
 HENNY PENNY CORP.
 EATON, OHIO 45320

37490

2-15. WIRING DIAGRAMS (Continued)

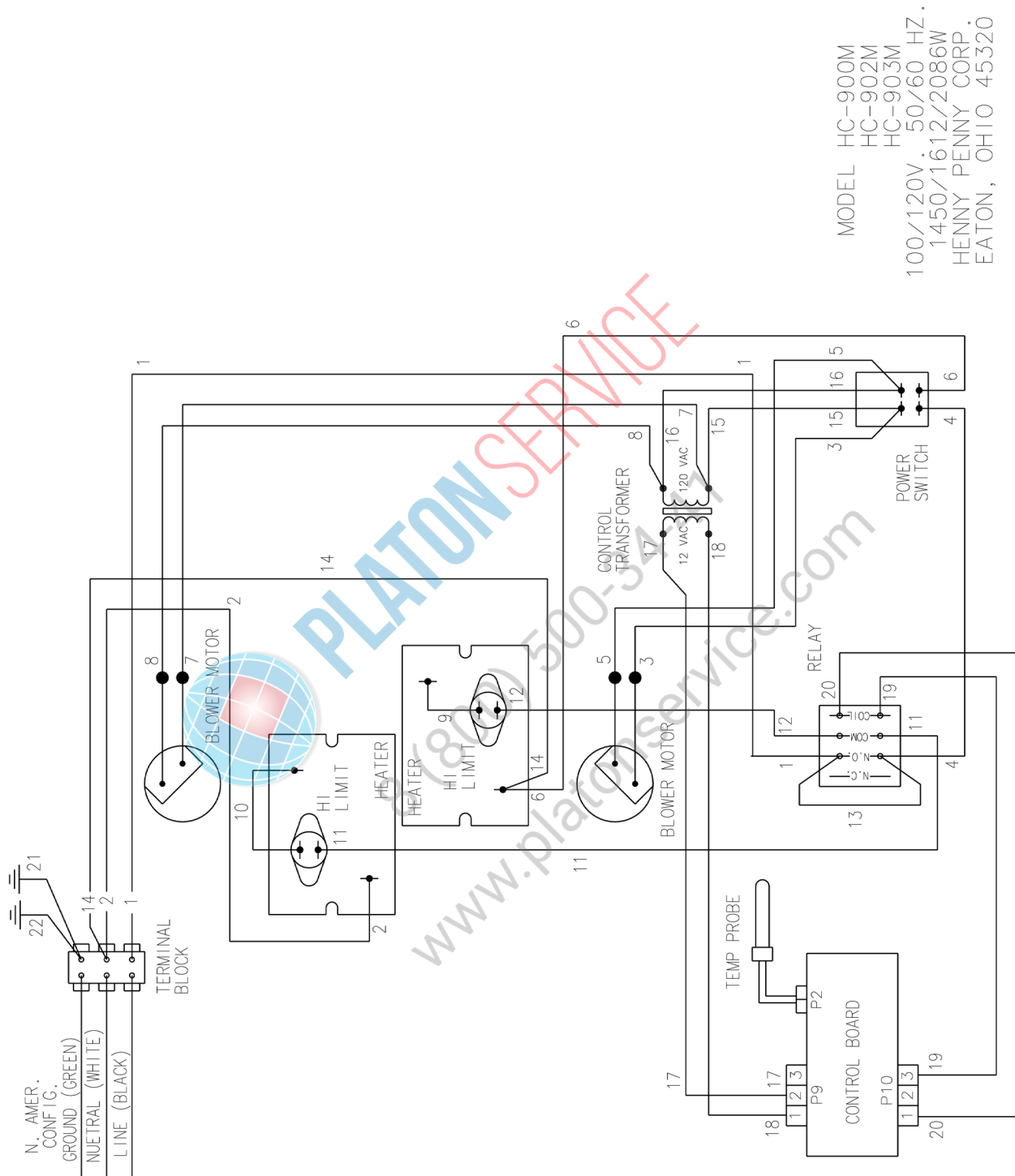

37491E

2-15. WIRING DIAGRAMS (Continued)

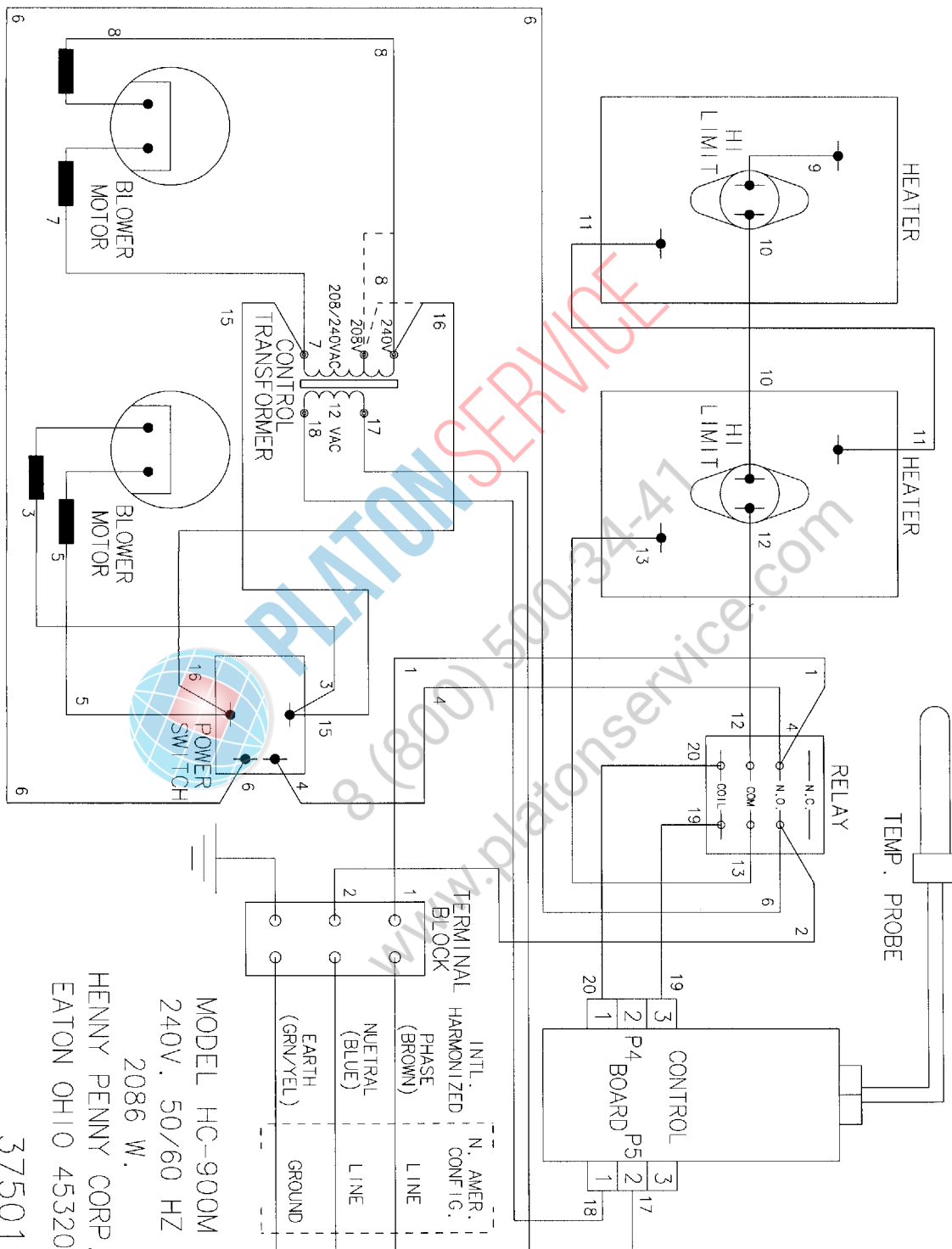

MODEL HC-900M
240V, 50/60 HZ
2086 W.
HENNY PENNY CORP.
EATON OHIO 45320
37501

2-15. WIRING DIAGRAMS (Continued)

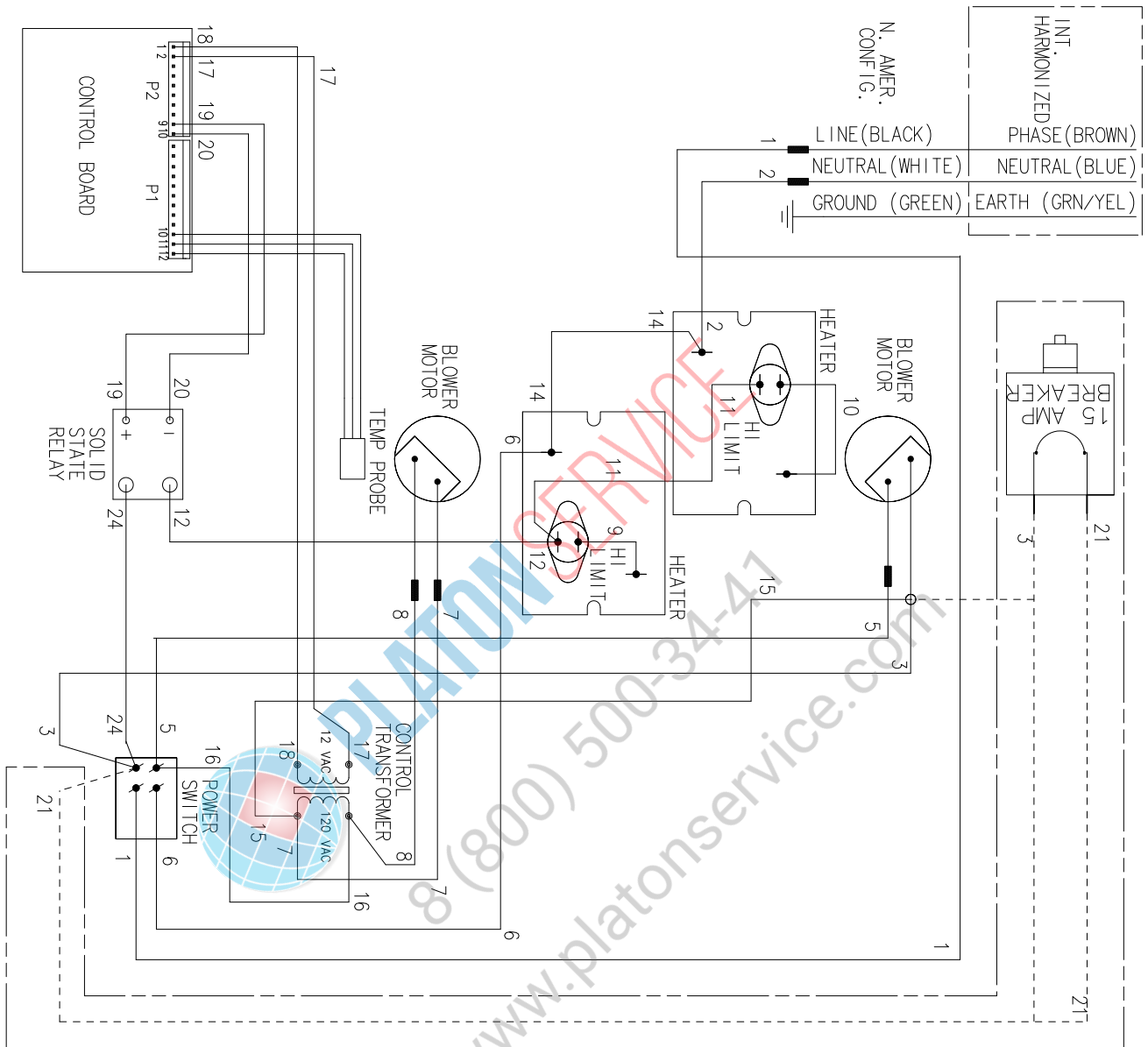

HC-900BC
120V 60 Hz
2086W
HENNY PENNY CORP.
EATON, OHIO 45320
54569

2-15. WIRING DIAGRAMS (Continued)

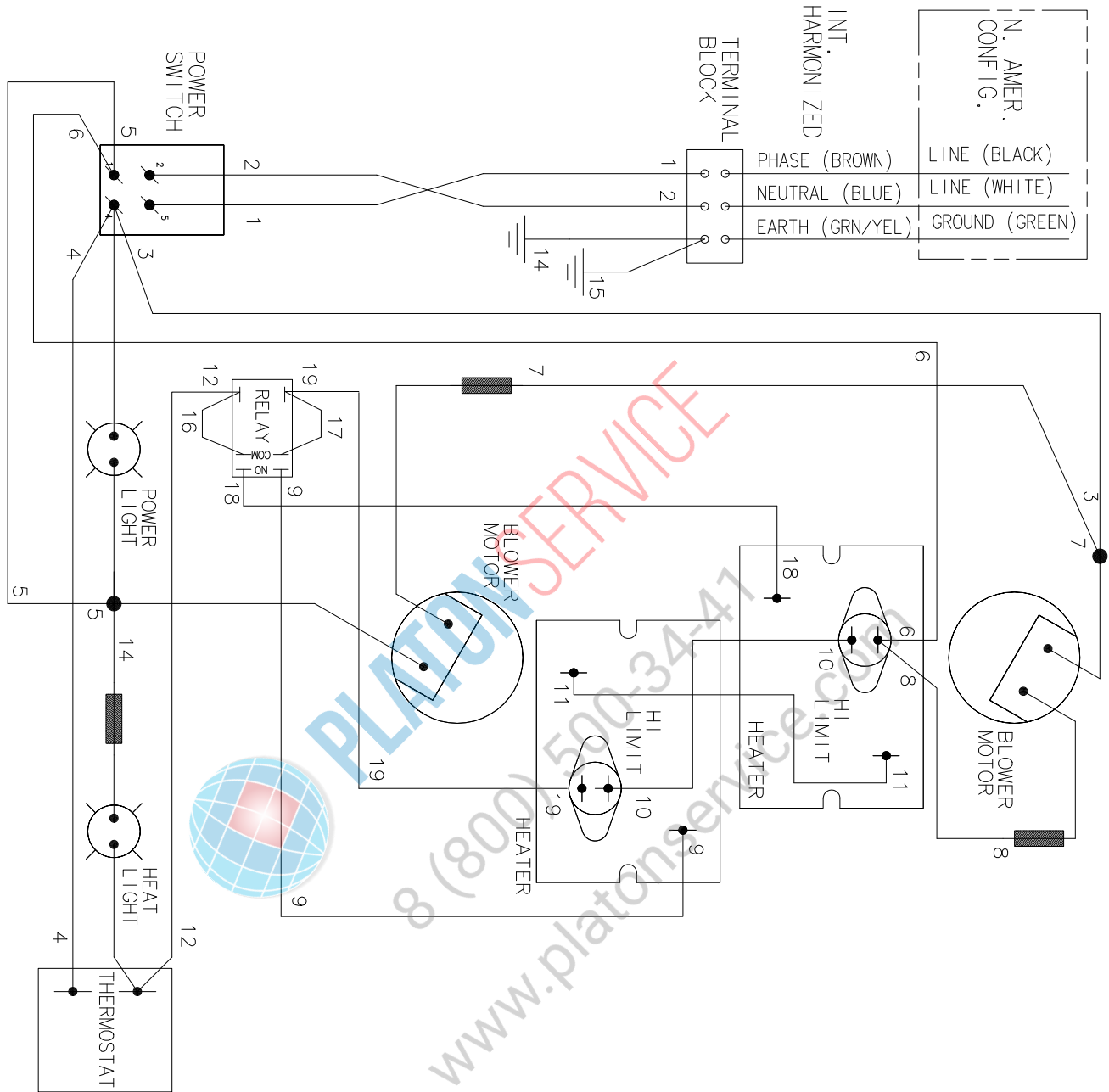

HC-900, HC-902
 HC-903, HC-906
 HC-908
 230V, 50/60 HZ
 1350W, 1900W
 HENNY PENNY CORP.
 EATON, OHIO 45320

44876

2-15. WIRING DIAGRAMS (Continued)

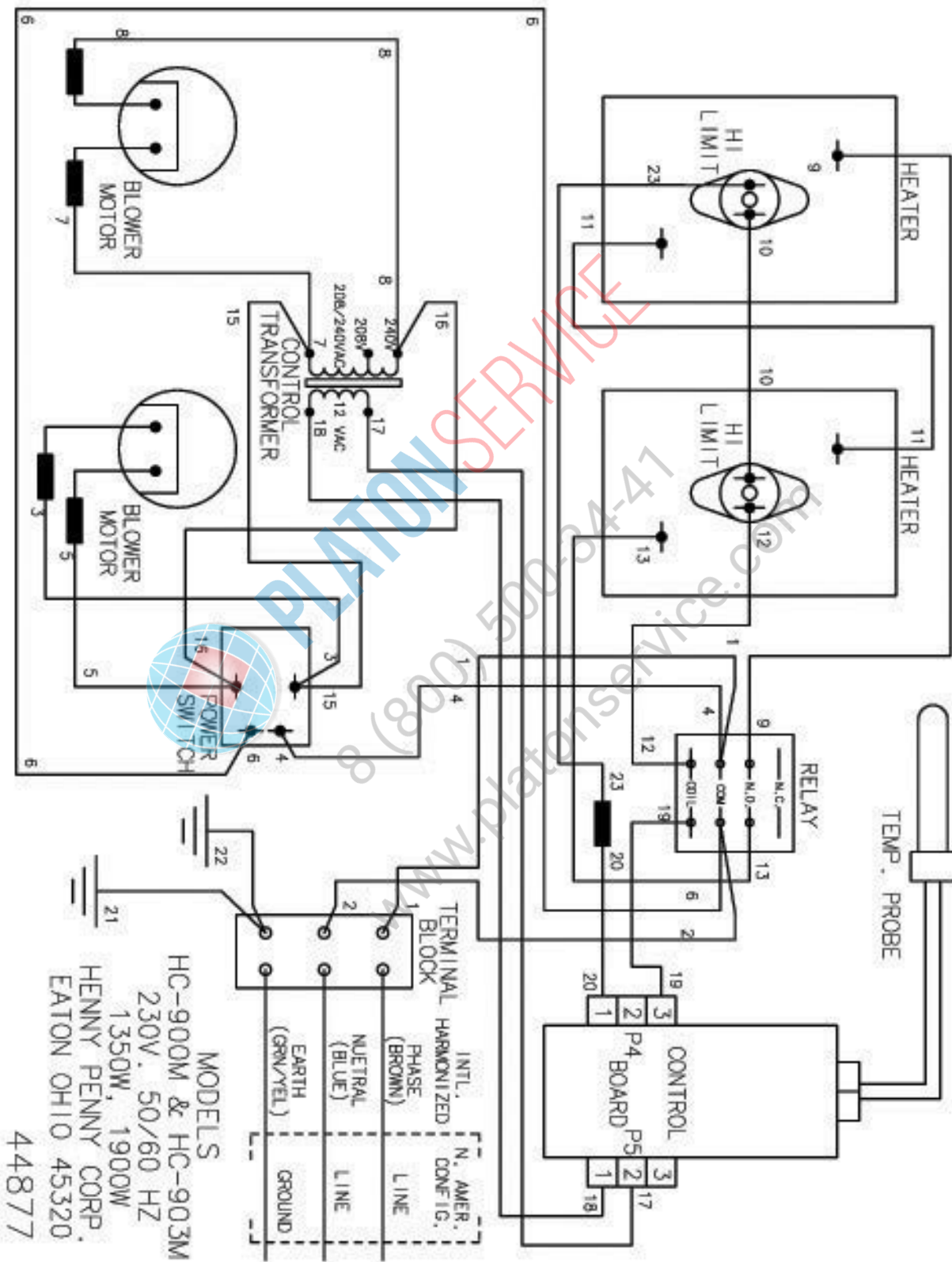

2-15. WIRING DIAGRAMS (Continued)

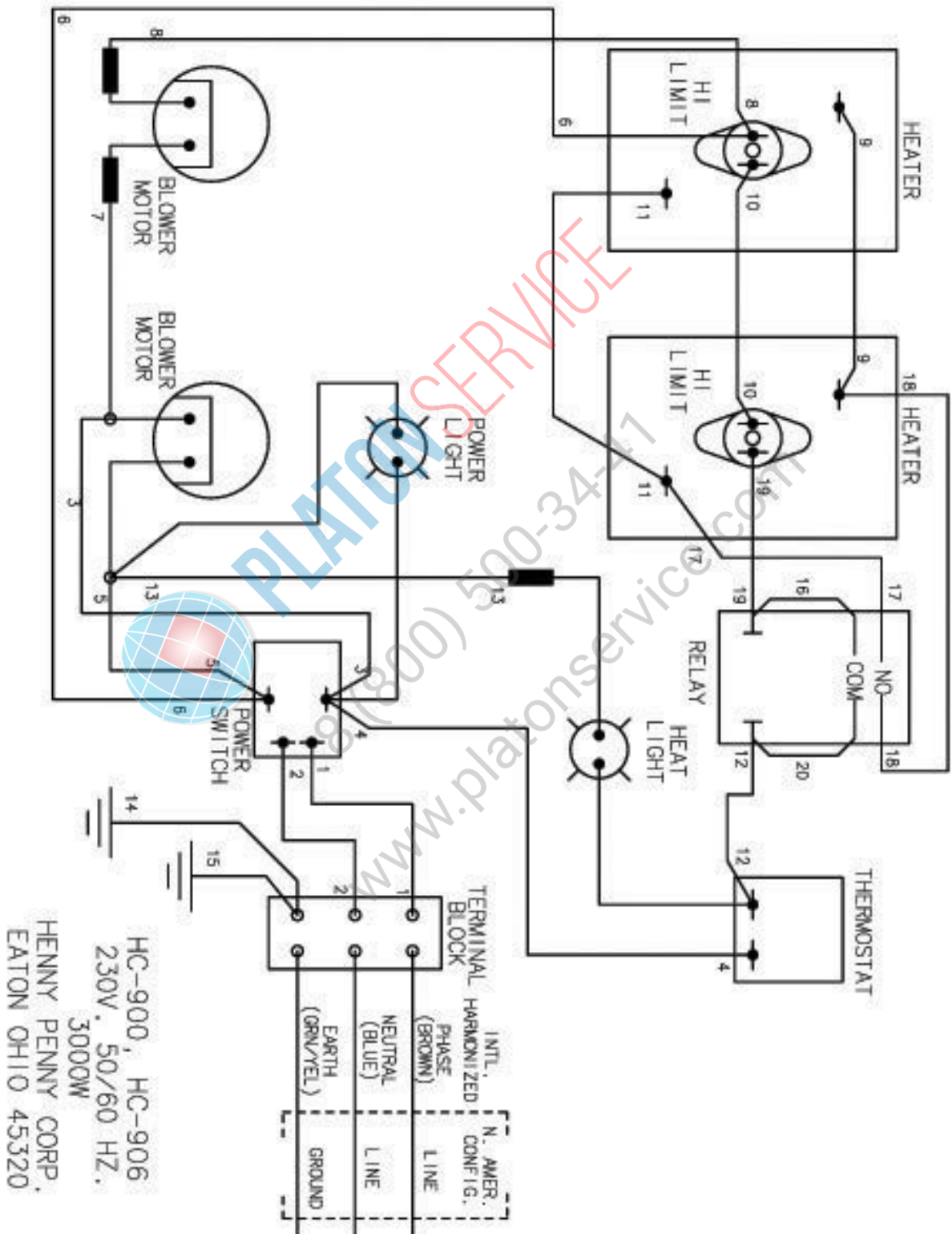

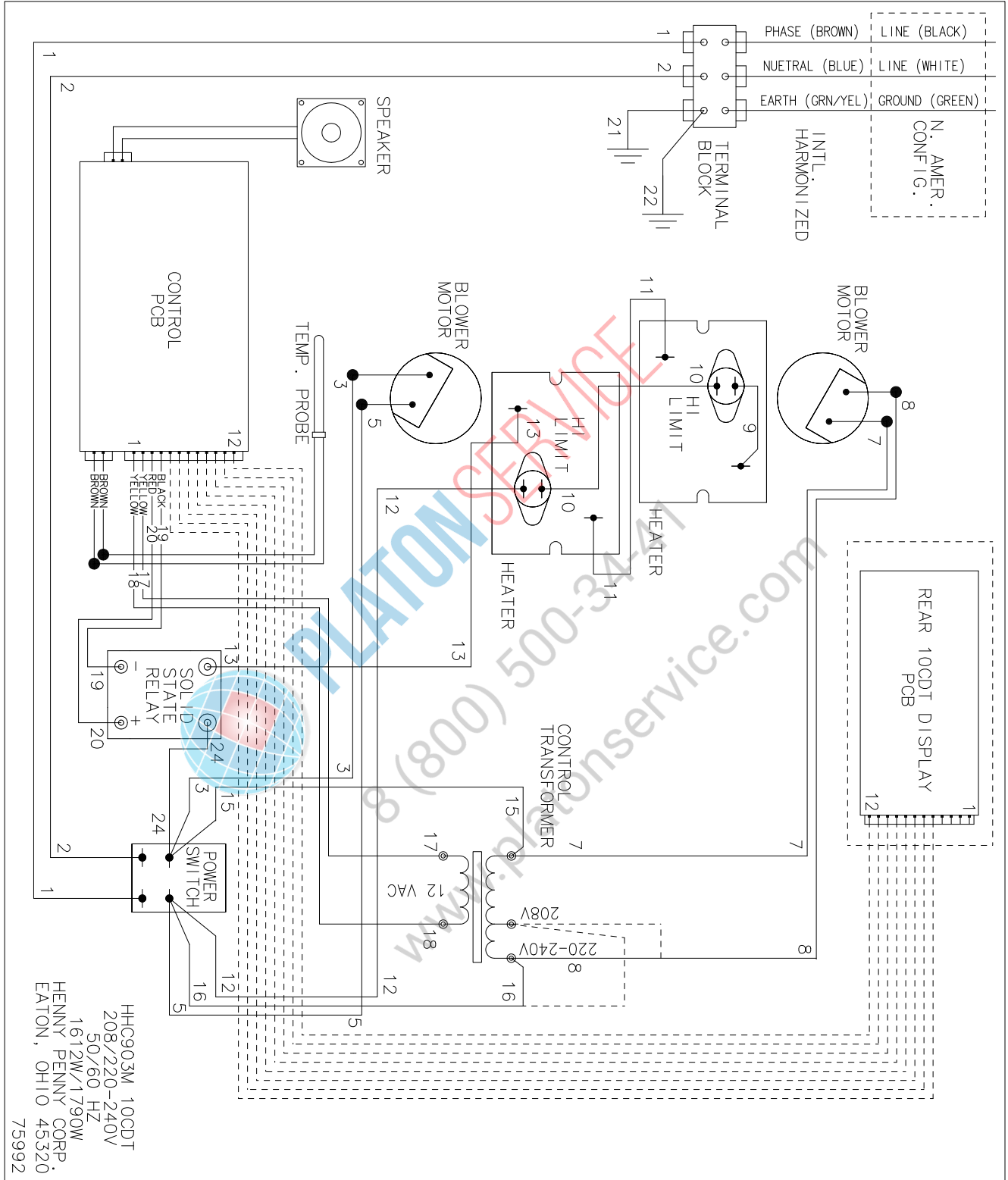

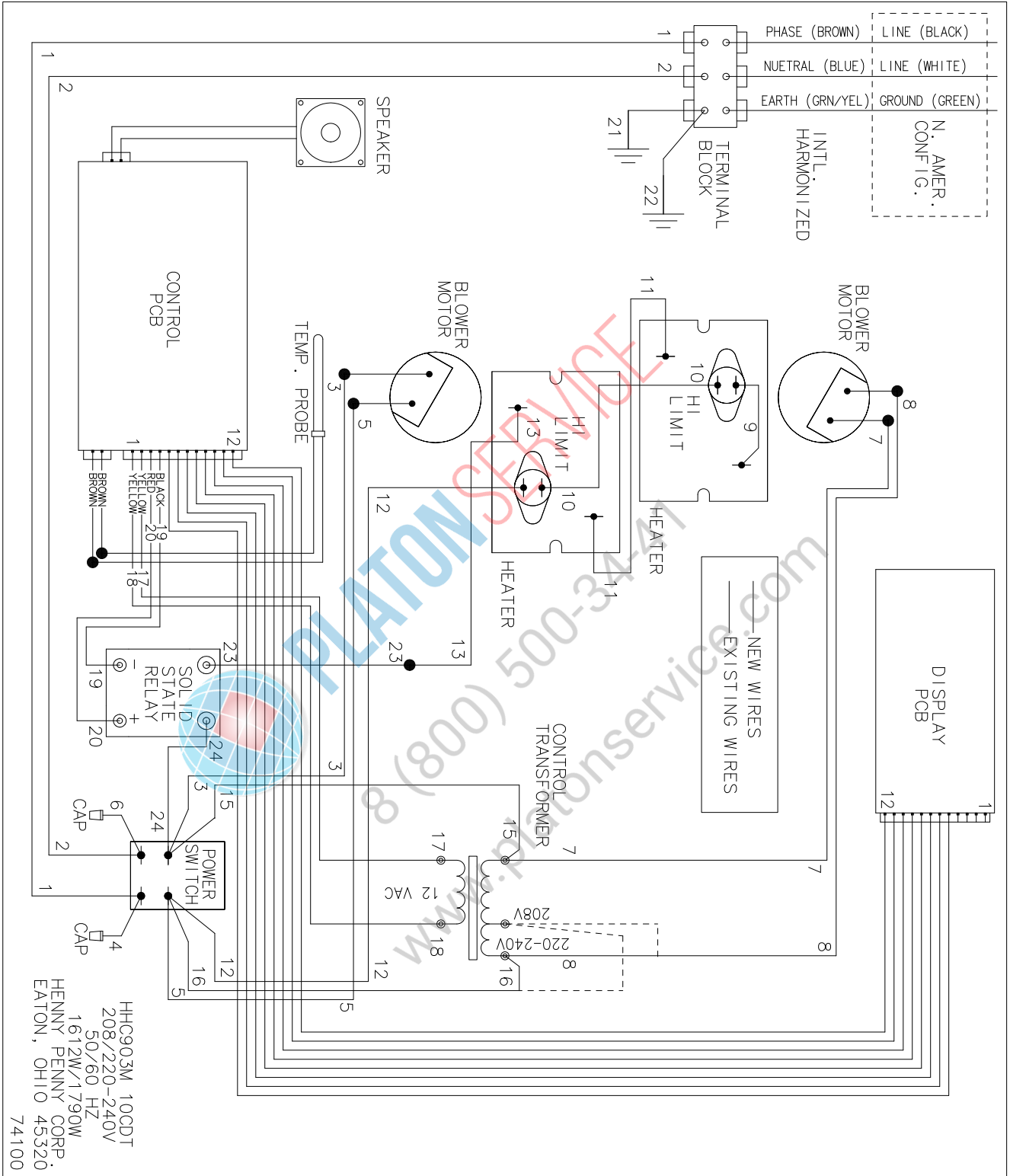

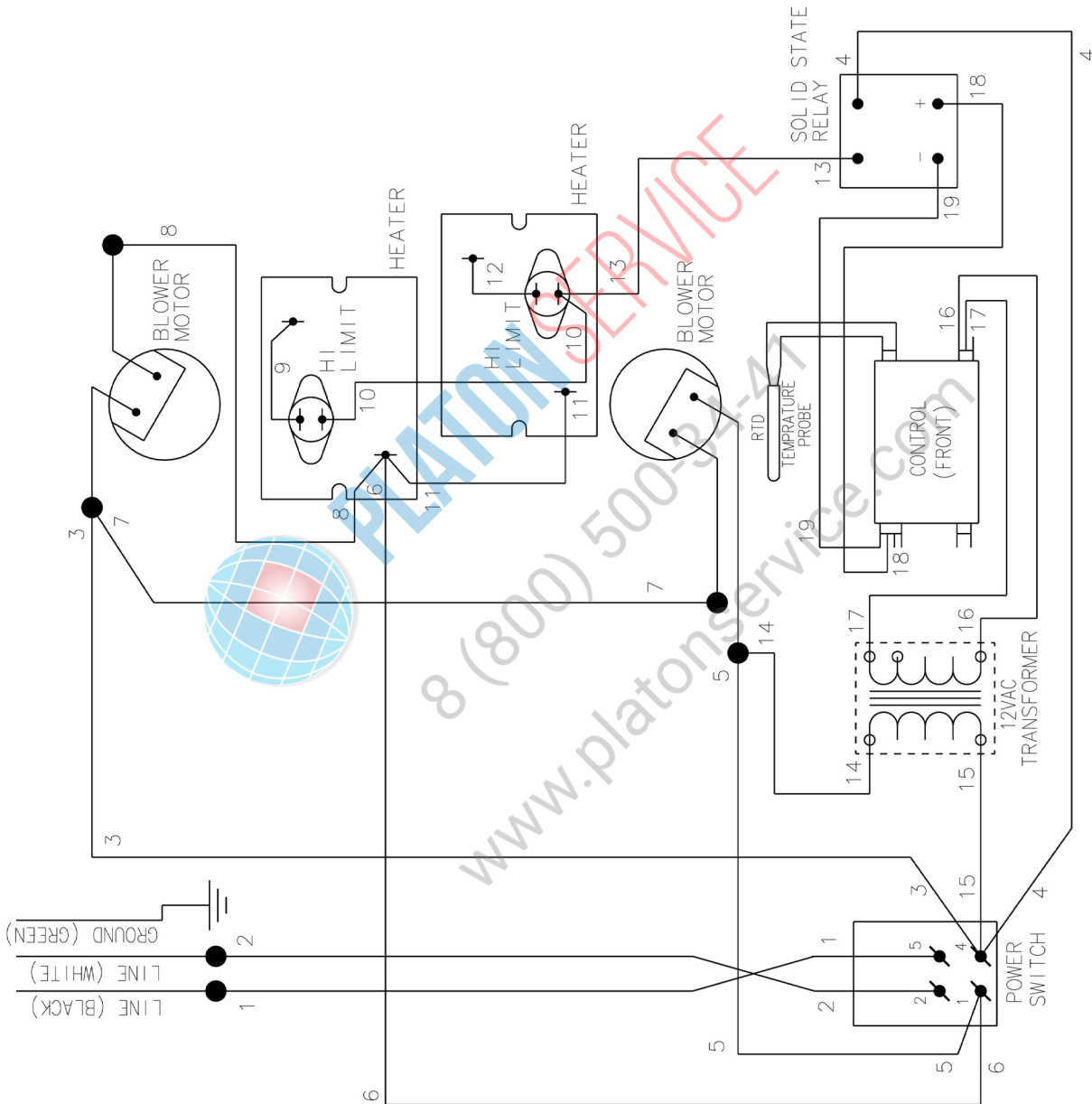

HC-900
120V 60 HZ
1586W
HENNY PENNY CORP.
EATON, OHIO 45320

69860

MODEL HC-900M
100V, 50/60 HZ
1450W
HENNY PENNY CORP.
EATON, OHIO 45320
76458B

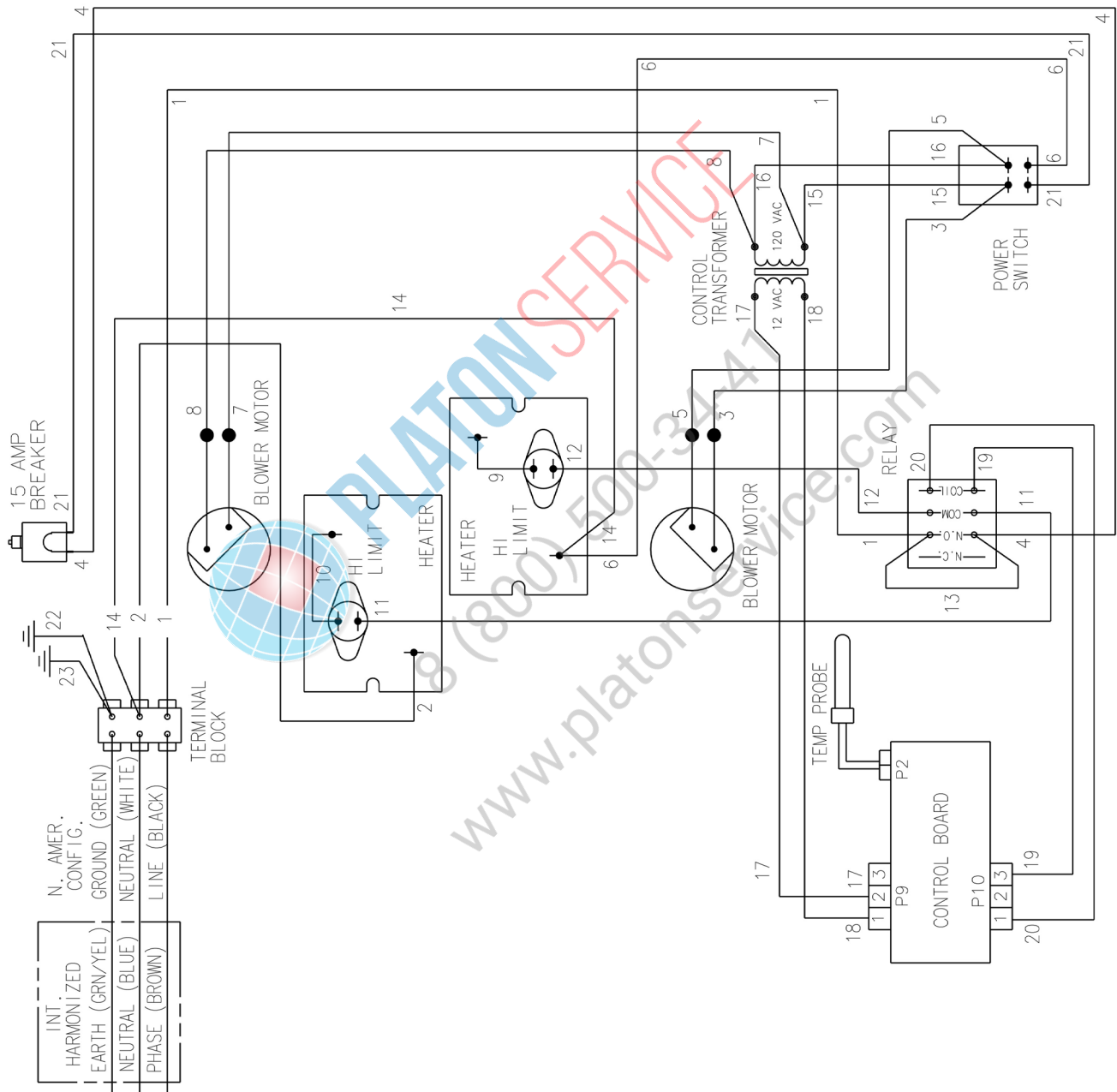

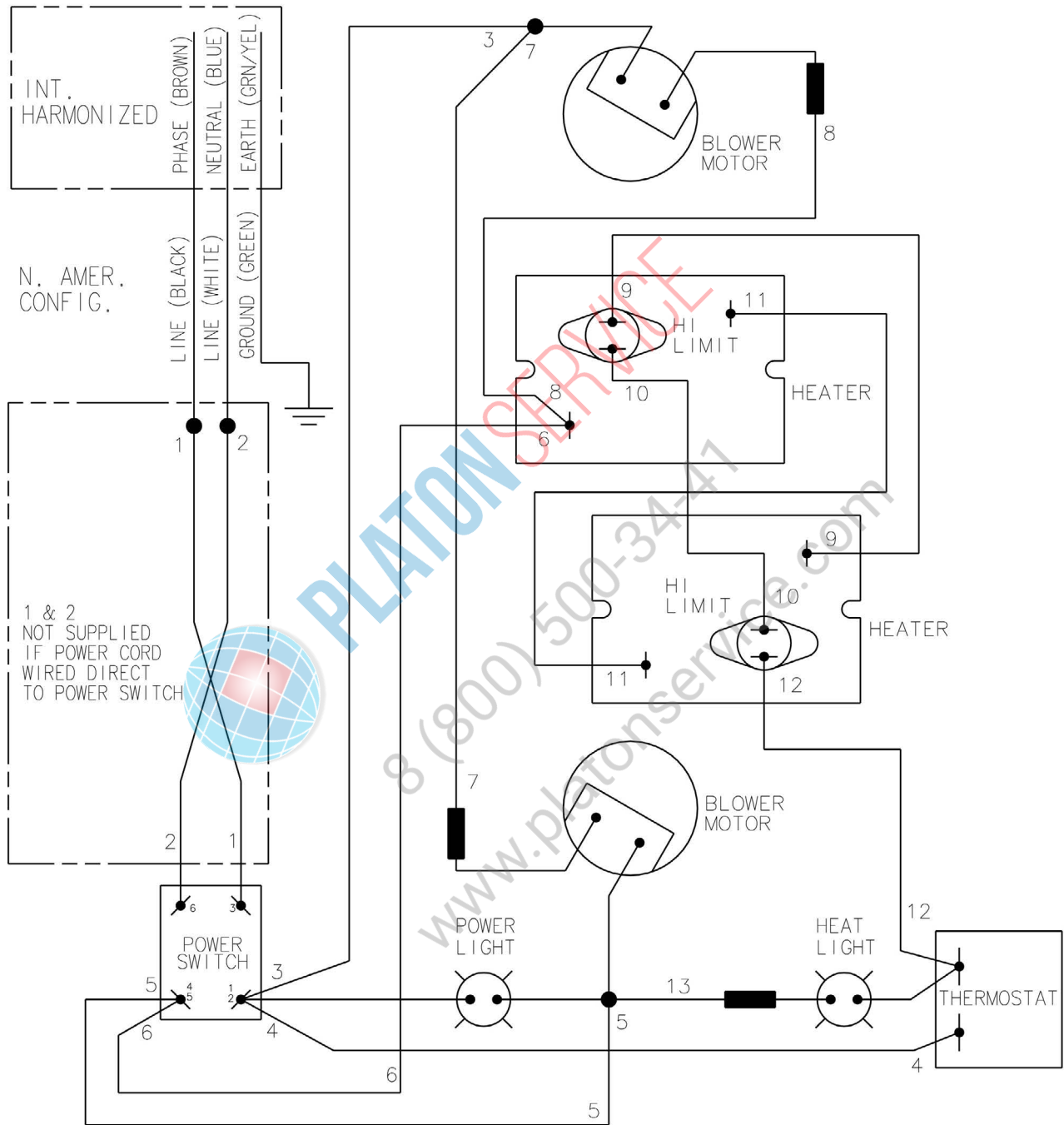

HHC-900 EM & HC-15, 208-240V/50 or 60 Hz/1 Phase, Non-UL, Non-CE

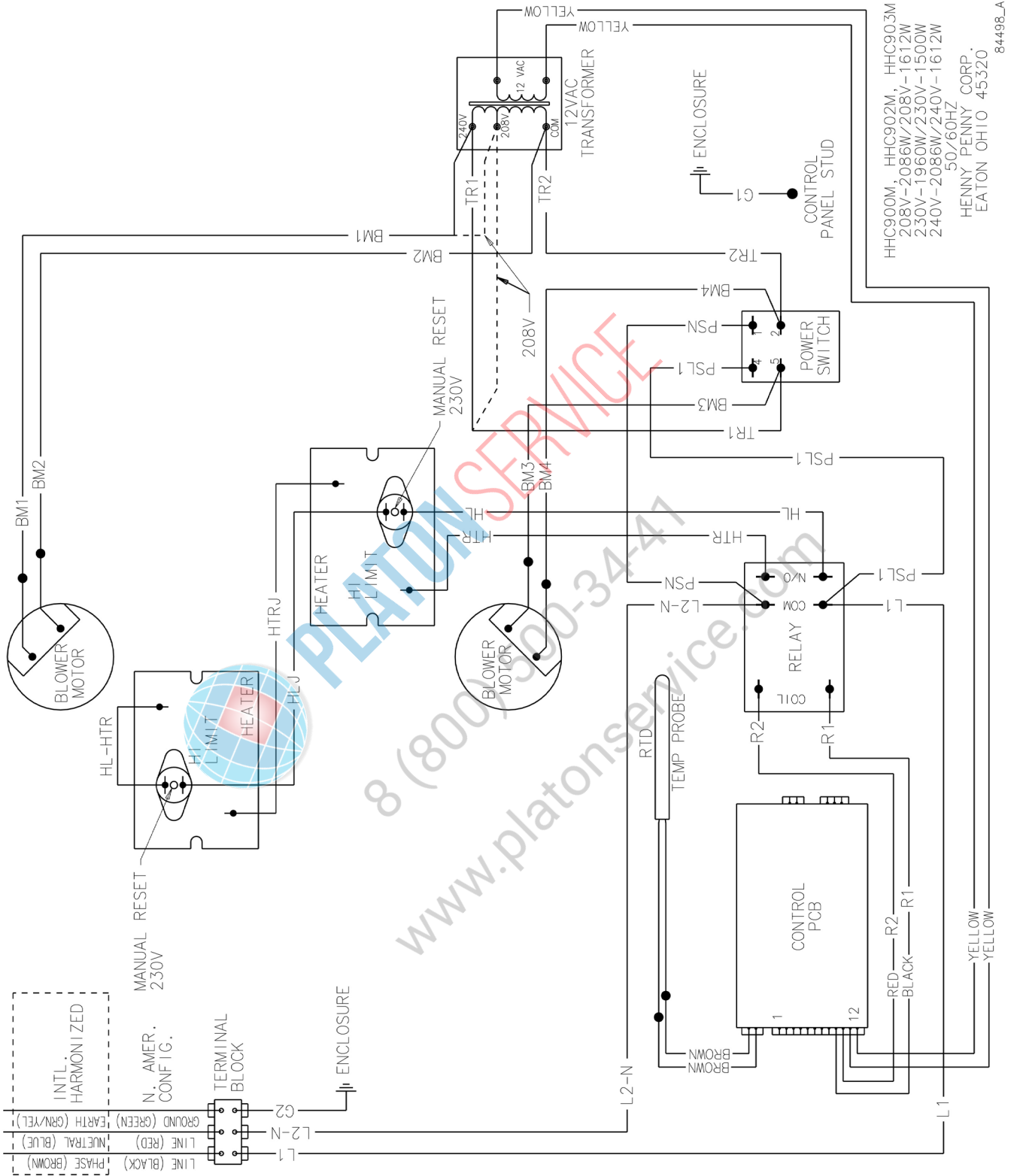

HHC900M, HHC902M, HHC903M
208V-2086W/208V-1612W
230V-1960W/230V-1500W
240V-2086W/240V-1612W
50/60HZ
HENNY PENNY CORP.
EATON OHIO 45320
84498_A

HHC-900 CDT, 208-240V/50 or 60 Hz/1 Phase, Non-UL, Non-CE

LIMITED WARRANTY FOR HENNY PENNY EQUIPMENT

Subject to the following conditions, Henny Penny Corporation makes the following limited warranties to the original purchaser only for Henny Penny appliances and replacement parts:

NEW EQUIPMENT: Any part of a new appliance, except baskets, lamps, and fuses, which proves to be defective in material or workmanship within two (2) years from date of original installation, will be repaired or replaced without charge F.O.B. factory, Eaton, Ohio, or F.O.B. authorized distributor. Baskets will be repaired or replaced for ninety (90) days from date of original installation. Lamps and fuses are not covered under this Limited Warranty. To validate this warranty, the registration card for the appliance must be mailed to Henny Penny within ten (10) days after installation.

FILTER SYSTEM: Failure of any parts within a fryer filter system caused by the use of the non-OEM filters or other unapproved filters is not covered under this Limited Warranty.

REPLACEMENT PARTS: Any appliance replacement part, except lamps and fuses, which proves to be defective in material or workmanship within ninety (90) days from date of original installation will be repaired or replaced without charge F.O.B. factory, Eaton, Ohio, or F.O.B. authorized distributor.

The warranty for new equipment covers the repair or replacement of the defective part and includes labor charges and maximum mileage charges of 200 miles round trip for a period of one (1) year from the date of original installation.

The warranty for replacement parts covers only the repair or replacement of the defective part and does not include any labor charges for the removal and installation of any parts, travel, or other expenses incidental to the repair or replacement of a part.

EXTENDED FRYPOT WARRANTY: Henny Penny will replace any frypot that fails due to manufacturing or workmanship issues for a period of up to seven (7) years from date of manufacture. This warranty shall not cover any frypot that fails due to any misuse or abuse, such as heating of the frypot without shortening.

0 TO 3 YEARS: During this time, any frypot that fails due to manufacturing or workmanship issues will be replaced at no charge for parts, labor, or freight. Henny Penny will either install a new frypot at no cost or provide a new or reconditioned replacement fryer at no cost.

3 TO 7 YEARS: During this time, any frypot that fails due to manufacturing or workmanship issues will be replaced at no charge for the frypot only. Any freight charges and labor costs to install the new frypot as well as the cost of any other parts replaced, such as insulation, thermal sensors, high limits, fittings, and hardware, will be the responsibility of the owner.

Any claim must be presented to either Henny Penny or the distributor from whom the appliance was purchased. No allowance will be granted for repairs made by anyone else without Henny Penny's written consent. If damage occurs during shipping, notify the sender at once so that a claim may be filed.

THE ABOVE LIMITED WARRANTY SETS FORTH THE SOLE REMEDY AGAINST HENNY PENNY FOR ANY BREACH OF WARRANTY OR OTHER TERM. BUYER AGREES THAT NO OTHER REMEDY (INCLUDING CLAIMS FOR ANY INCIDENTAL OR CONSEQUENTIAL DAMAGES) SHALL BE AVAILABLE.

The above limited warranty does not apply (a) to damage resulting from accident, alteration, misuse, or abuse; (b) if the equipment's serial number is removed or defaced; or (c) for lamps and fuses. THE ABOVE LIMITED WARRANTY IS EXPRESSLY IN LIEU OF ALL OTHER WARRANTIES, EXPRESS OR IMPLIED, INCLUDING MERCHANTABILITY AND FITNESS, AND ALL OTHER WARRANTIES ARE EXCLUDED. HENNY PENNY NEITHER ASSUMES NOR AUTHORIZES ANY PERSON TO ASSUME FOR IT ANY OTHER OBLIGATION OR LIABILITY.

Revised 01/01/07

SECTION 3. PARTS INFORMATION

3-1. INTRODUCTION

This section identifies and lists the replaceable parts of the Henny Penny Model HHC-900 heated holding cabinet.

3-2. GENUINE PARTS

Use only genuine Henny Penny parts in your cabinet. Using a part of lesser quality or substitute design may result in cabinet damage or personal injury.

3-3. HOW TO FIND PARTS

To find items you want to order from the Parts List, proceed as follows:

1. Referring to the illustration in this section, find the part item number of the part needed.
2. Find the item number in the parts list, which shows the Henny Penny part number, a description of the part, any model or usage limitations, and the quantity of parts used.

3-4. HOW TO ORDER



Once the parts you want to order have been found in the Parts List, write down the following information:

Example:

Item number	44
Part number	14635
Description	Power Switch

From the data plate list the following information:

Example:

Product number	HHC-900.0
Serial number	00179
Voltage	120

3-4. HOW TO ORDER
(Continued)

The following table has been provided as a sample format for you to use in preparing your spare parts orders. By providing all the entries, your distributor will be able to ensure the correct parts will be sent to you. Also, by prepayment your order will be expedited.

FROM PARTS LIST			YOUR ORDER		
Item Number	Part Number	Description	Quantity Ordered	Price Each	Total
46	25183	Thermometer			
Product No. <u>HHC-900.0</u>			Serial No. <u>00179</u>		Voltage <u>120</u>

3-5. PRICES



Your distributor has a priced parts list and will be glad to inform you of the cost of your parts order.

3-6. DELIVERY

Commonly replaced items are stocked by your distributor and will be sent out when your order is received. Other parts will be ordered by your distributor from Henny Penny Corporation. Normally, these will be sent to your distributor within three working days.

3-7. WARRANTY

All replacement parts (except lamps and fuses) are warranted for 90 days against manufacturing defects and workmanship. If damage occurs during shipping, notify the sender and the carrier at once so that a claim may be properly filed. Refer to warranty in the front of this section for other rights and limitations.

3-8. RECOMMENDED SPARE PARTS FOR DISTRIBUTORS

Recommended replacement parts, stocked by your distributor, are indicated with √ in the parts lists. Please use care when ordering recommended parts, because all voltages and variations are marked. Distributors should order parts based upon common voltages and equipment sold in their territory.

UL & CE Approved - HHC-900/902/903/904/906/908

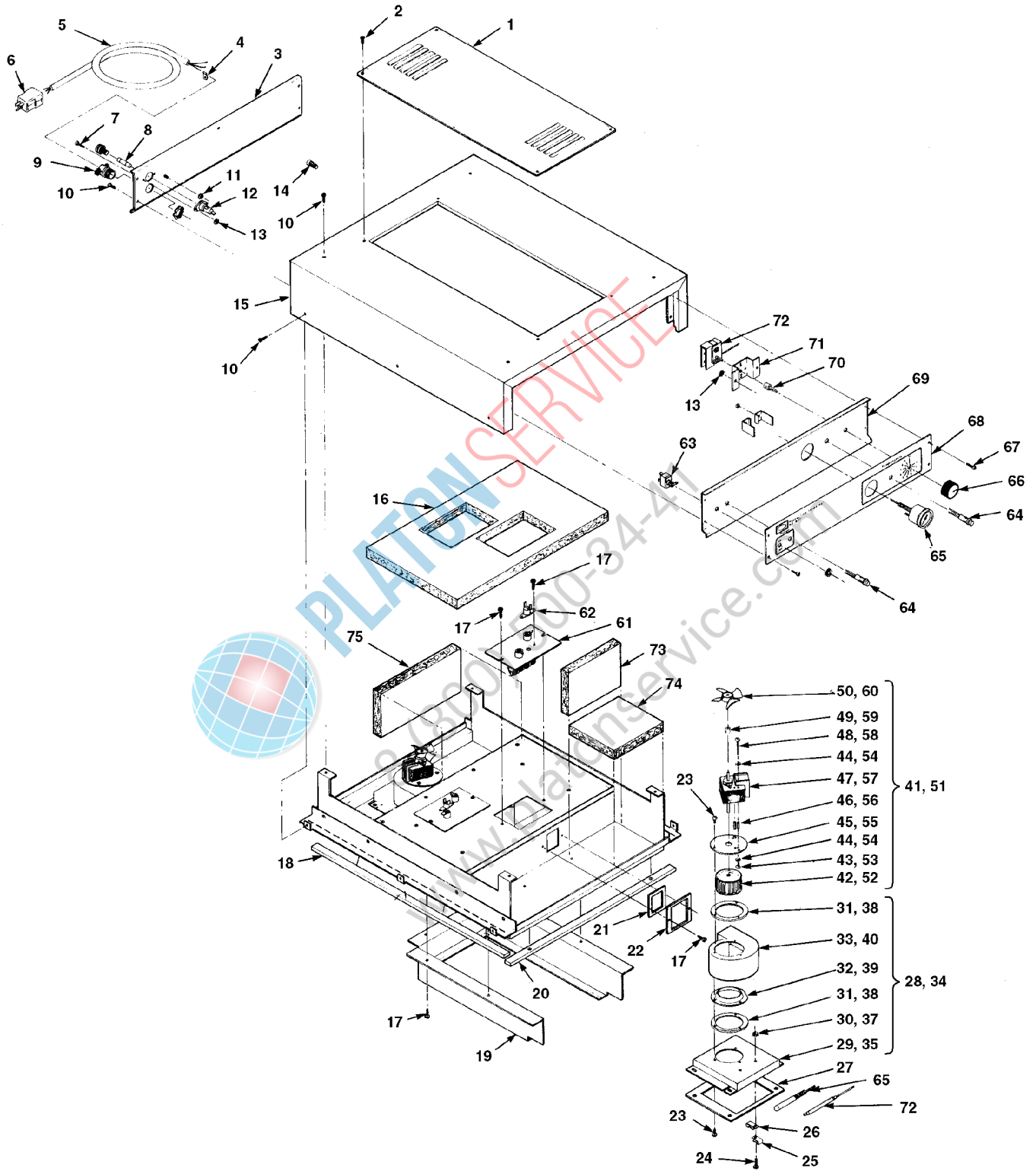

Figure 3-1. Control Module Assembly - UL & CE Approved

UL & CE Approved - HHC-900/902/903/904/906/908

<u>Figure No.</u> <u>& Item No.</u>	<u>Part No.</u>	<u>Description</u>	<u>Quantity</u>
3-1		Control Module Assembly - UL & CE Approved	
1	25704	Panel - Access	1
1	51209	Panel -Access - C E	1
2	SC01-053	Screw #8-32 x 1/2 PH RHD	4
3	48993	Panel - Rear (208/240V) S/A	1
3	71092	Panel - Rear (120V) S/A	1
3	25944	Panel Rear S/A: HC-903	1
3	28121	Panel - Rear HHC-906; HHC-908	1
3	49018	Panel - Rear - CE	1
4	EC04-002	Terminal Flag #10-10-12 Ga	1
5	MS01-212	Cable #12/3, 2,000W/120V	8 Ft.
5	MS01-175	Cable #14/3; 1500W/120V & 3000W/240V	8 Ft.
5	67390	Power Cord Assy. - Twist - 120V/20A	1
5	67472	Power Cord Assy. - 125V, 20 Amp	1
5	44857	Power Cord Assy. - 1.0MM - CE	1
5	71119	Power Cord Assy. - 1.5MM - HHC-906 - CE	1
5	71120	Power Cord Assy. - Canada - 120V/30A-RT Angle	1
5	68412	Power Cord Assy. - Canada - 208/240/20A	1
5	68413	Power Cord Assy. - 208/240/20A	1
5	71384	Power Cord Assy. - Harmonized - Int'l. - 240V	1
6	25765	Plug 125V, 20 Amp; Used on 2000W/120V	1
6	25764	Plug 125V, 15 Amp, Used on 1500W/120V	1
6	63943	Plug 250V, 20 Amp; Used on 3000W/240V	1
6	28543	Plug - Twist - 120V/20A	1
6	71717	Plug - 120V, 30 Amp - RT Angle - Canada	1
7	SC01-010	Screw #6-32 x 112 pH PHD	2
A 8	EF02-007	Fuse 15 Amp	1
9	EF02-124	Connector - Cable 3/4	1
10	SC02-023	Screw 48-B x 3/8 pH THD	15
11	NS02-001	Nut #10-32 Hex Keps	1
A 12	EF02-006	Fuse Holder	1
13	NS02 005	Nut #6-32 Hex Keps	2
14	EC01-010	Wire Nut 12-18 Ga	2
15	76396	Top - Enclosure	1
15	28153	Top HHC-906, HHC-908	1
16	26225	Insulation - Cover	1
17	SC02-041	Screw #8-18 x 7/16 PH IND XTRNL TORX	18
18	25620	Seal	2
19	25670	Cradle	1
20	25624	Seal	2
21	25619	Gasket - Blower Outlet	2
22	25618	Gasket Retainer	2
23	SC02-012	Screw #12-AB x 3/8 Ph PHD	2
24	SC01-055	Screw #1 0-32 x 3/4 Hex HD	2
25	EF02-031	Clamp 1/4 x 3/8"	2
26	EF02-033	Clamp 7/16 x 3/8"	2
27	25627	Gasket	2
28	25872	Blower Box Assembly (903 and all others)	1 or 2
29	25616	Box, Blower	1

√ recommended parts

UL & CE Approved - HHC-900/902/903/904/906/908

<u>Item No.</u>	<u>Part No.</u>	<u>Description</u>	<u>Quantity</u>
30	NS02-001	Nut	2
31	25698	Gasket, Blower Plate.....	2
32	25622	Flange, Inlet	1
33	25623	Housing, Blower	1
34	25941	Blower Box Assembly (903 only)	1
35	25924	Rear Box, Blower	1
36*	25942	Hose Coupling	1
37	NS02-001	Nut	2
38	25698	Gasket, Blower Plate.....	2
39	25622	Flange, Inlet	1
40	25623	Housing, Blower	1
41	25753	Blower Motor Assembly (120V)	2
42	25621	Wheel, Blower, Std.	2
43	SC01-023	Screw	8
44	LW02-010	Lockwasher	8
45	37157	Plate, Blower.....	2
46	81606	Spacer, Motor.....	8
A 47	25751	Motor (120V).....	2
48	SC01-091	Screw	4
49	25768	Spacer, Fan.....	2
A 50	25706	Fan, Cooling.....	2
51	14249	Blower Motor Assembly (240V)	2
52	52240	Wheel, Blower, Int'l.....	2
53	SC01-023	Screw	8
54	LW02-010	Lockwasher	8
55	37157	Plate, Blower.....	2
56	81606	Spacer, Motor.....	8
A 57	25752	Motor (240V).....	2
58	SC01-091	Screw	8
59	25768	Spacer, Fan.....	2
A 60	25706	Fan, Cooling.....	2
A 61	51279	Heater 120V/1000W	2
A 61	74870	Heater 100V/1000W	2
A 61	67627	Heater 240V/1500W	2
A 61	51278	Heater 120V/750W	2
A 62	18201	High Limit Thermostat	2
A 62	59272	High Limit Sensor (manual reset)-CE	2
A 63	14635	Power Switch (toggle)	1
A 63	72277	Black Rocker Switch - CDT	1
A 63	52224	Rocker Switch - CDT - CE	1
B 64	16624	Indicator Light - Red.....	2
B 64	54085	Indicator Light - CE - Green.....	2
B 65	14250	Thermometer.....	1
66	25863	Knob - Thermostat	1
67	SC02-030	Screw #8-B x 3/8 PH THD Black Oxide.....	4
68	25717	Label Control Panel	1
68	44024	Label Control Panel - KFC	1
68	61445	Label Control Panel-Pollo Campero.....	1
68	61523	Label Control Panel-Pollo Campero - HHC-903.....	1

√ recommended parts/* not shown

UL & CE Approved - HHC-900/902/903/904/906/908

<u>Item No.</u>	<u>Part No.</u>	<u>Description</u>	<u>Quantity</u>
68	25948	Label Control Panel; Std. HHC-900 - Vented	1
68	44023	Label Control Panel KFC- Vented.....	1
68	49119	Label Control Panel; HHC-906/908 (rocker-after Nov. 1, 2005).....	1
68	28188	Label Control Panel; HHC-906 (toggle-before Nov. 1, 2005)	1
68	28190	Label Control Panel; HHC-908 (toggle-before Nov. 1, 2005)	1
68	85250	Label Control Panel KFC - CDT Vented.....	1
68	45616	Label Control Panel-HHC-906 Auto Water-CE	1
68	49060	Label Control Panel - CE - Std. HHC-900	1
68	61470	Label Control Panel - HHC-903 - Wendy's.....	1
69	25786	Panel Control S/A HHC-900	1
69	69856	Panel Control S/A HHC-900 - SimpleHold.....	1
69	25947	Panel Control S/A HHC-903	1
69	28182	Panel Control S/A HHC-906/908 (rocker-after Nov. 1, 2005).....	1
69	14684	Panel Control S/A HHC-906/908 (replaces toggle-before Nov. 1, 2005)	1
69	49054	Panel Control S/A - CE - Std. HHC-900.....	1
71	25241	Bracket Thermostat Mount.....	1
70	25263	Extension Thermostat Shaft.....	1
A 72	14209	Thermostat w/clips	1
73	25734	Insulation 5 x 7 x 1	2
74	25733	Insulation 6 x 6 1/2 x 1.....	4
75	25735	Insulation 5 x 10 1/2 x 1	2
76*	25950	Control Cable; HHC-903.....	1
77*	27849	Actuator HHC-903	1
78*	51214	Vent Housing - CE	2
79*	04158	Wiring Kit (higher wattage)-E/M-Top Cord.....	1
79*	01460	Wiring Kit (higher wattage)-E/M-Rear Cord	1
79*	01461	Wiring Kit (higher wattage)-S/S Controls.....	1
79*	14903	KIT - 900 SW ASSY 100V EM Top CD	1
79*	14904	KIT - 900 SW ASSY 100V EM Rear CD.....	1
79*	14905	KIT - 900 Switch ASSY 100V EM	1
79*	14906	KIT - 900M Wiring 100V CDT	1
A 83*	ME90-003	Relay - 12V Coil 20A 240Vac - CE.....	1
HHC-900/903 CDT Only - 13, 10, 6 & 5 Timers			
3	37147	Rear Panel Assy.	1
5	37556	Power Cord Assy.	1
A 63	43768	Power Switch.....	1
69	37395	Control Panel Weld Assy - 903 - 6 Timer.....	1
69	37285	Control Panel Weld Assy - Vented.....	1
69	30951	Control Panel Weld Assy - Not Vented.....	1
B 72	54577	Assy-Temperature Sensor (Boston Market)	1
B 72	29523	Probe Assy.	1
A 80	83758	Control PCB - 3 digit - 13 Timer (SN:DA1005053 and above).....	1
A 80	83760	Control PCB - 3 digit - 5 Timer (SN:DA1005053 and above).....	1
A 80*	140115	Kit- Control PCB - 3 digit - 13 Timer (SN: GV083IE - DA1005052)	1
	83761	Control PCB - 3 digit - 13 Timer.....	1
A 80*	140116	Kit- Control PCB - 3 digit - 5 Timer (SN: GV083IE - DA1005052)	1
	83762	Control PCB - 3 digit - 5 Timer	
A 80*	31910RB	Display PC Board Assy - 2 digit - 13 Timer; GV082IE and below...	1
A 80*	37374RB	Display PC Board Assy - 2 digit - 6 Timer; GV082IE and below.....	1
A 80*	73970RB	Display PC Board Assy - 3 digit - 10 Timer (McD's 903)	1

√ recommended parts/*not shown

UL & CE Approved - HHC-900/902/903/904/906/908

<u>Item No.</u>	<u>Part No.</u>	<u>Description</u>	<u>Quantity</u>
A 81*	78082RB	Control PC Board Assy - 3 digit - 10 Timer (McD's 903).....	1
A 81*	73968RB	Control PC Board Assy-2 digit-5 & 13 Timer; GV082IE and below	1
A 81*	70047RB	Control PC Board Assy - 2 digit - 6 Timer; GV082IE and below.....	1
B 82*	40500	Replaceable Beeper-3 Digit; GV083IE and above	1
B 82*	36210	Replaceable Beeper-2 Digit; GV082IE and below	1
A 83*	ME90-003	Relay 12V coil	1
A 84*	30978	Transformer 115V	1
A 84*	92406	Transformer 240V	1
98*	14871	KIT - 903 CVSRN 5CDT to 10CDT (Front to Back).....	2
99*	14885	KIT - 903 CVSRN 5CDT to 10CDT (Front to Front)	2
100*	14774	KIT - 900 120V KFC PRGM THERM.....	1
101*	14775	KIT - 900 230/240V KFC PRGM THERM.....	1
102*	14918	KIT - 903 CVSRN - STACKED	1
HHC-900 CDT Decals			
68	33874	Decal - KFC Vented - 3 digit	1
68	43952	Decal - KFC Non Vented - 3 digit.....	1
68	30950	Decal - GM 900 - 3 digit.....	1
68	31901	Decal - 903 - 6 Timer - Vented - 2 digit.....	1
68	31931	Decal - 903 - 6 Timer - Non Vented - 2 digit.....	1
68	52347	Decal - GM 903 - 5 Timer - 3 digit.....	1
68	55180	Decal - 13 Timer - 903 - 3 digit (Churches).....	1
68	61443	Decal - 900 Pollo Campero.....	1
HHC-900 CDT-5 Timers-KFC			
68	43073	Control Panel Decal	1
A 80*	51117RB	Display PC Board	1
	140115	Kit-HC90X 13 Timer Replacement	1
	140116	Kit-HC90X 5 Timer Replacement	1
A 81*	39167RB	--Control PC Board	1
B 82*	40500	Replaceable Beeper.....	1
A 84*	30978	Transformer.....	1
Boston Market HHC-900			
68	54511	Decal	1
A 72	54577	Temperature Sensor Assy.....	1
A 81*	54571	PC Board Assy.	1
A 83*	40645	Relay	1
A 84*	30978	Transformer.....	1
SimpleHold - HHC-900			
A 61	51278	Heater 120V/750W	1
68	69894	Decal	1
A 72	29523	Temperature Sensor Assy.....	1
A 81*	69843	PC Board Assy.	1
A 83*	40645	Relay	1
A 84*	30978	Transformer.....	1

√ recommended parts/*not shown

UL & CE Approved - HHC-900/902/903/904/906/908

<u>Item No.</u>	<u>Part No.</u>	<u>Description</u>	<u>Quantity</u>
C.E. Parts			
5	44857	Power Cord Assy.....	1
A 63	52224	Rocker Switch - CDT - CE	1
A 63	43768	Power Switch - Plastic	1
68	49038	Decal - Control Panel - HHC-900.....	1
68	49060	Decal - Control Panel-Vented-HHC-903	1
68	49086	Decal - Control Panel-KFC-HHC-900.....	1
68	49118	Decal - Control Panel-w/Vent-HHC-906/908	1
Vented Control Module			
85*	48990	Rear Panel Studweld Assy (Full) 900	1
85*	25944	Rr Pnl Studweld Assy (1/3) 903 (SN: DA0506014 & below) ..	1
85*	68859	Rear Panel Studweld Assy (1/3) 903 (SN: DA0506015 & up).	1
85*	28123	Rear Panel Studweld Assy-906/908.....	1
86*	28155	Cable - E/M.....	1
86*	25950	Cable - CDT	1
87*	25964	Hose - Intake	1
88*	25963	Hose - Exhaust	1
89*	25977	Hose Clamp.....	4
90*	25942	Coupling - Hose	1
91*	25999	Control Panel Stud Assy	1
92*	38429	Vent Control Arm.....	1
93*	38367	Knob - Vented Module.....	1
94*	27927	Spacer - Slide Vent (SN: DA0506014 & below)	1
94*	68574	Spacer - Slide Vent (SN: DA0506015 & above).....	1
95*	27828	Slide - Vent - Back (SN: DA0506014 & below).....	1
96*	28092	Slide - Vent - Blower - Box (SN: DA0506014 & below).....	1
97*	25919	Slide - Vent (SN: DA0506014 & below)	1
97*	68573	Slide - Vent (SN: DA0506015 & above)	1

√ recommended parts/*not shown

UL & CE Approved - HHC-900/902/903/904/906/908

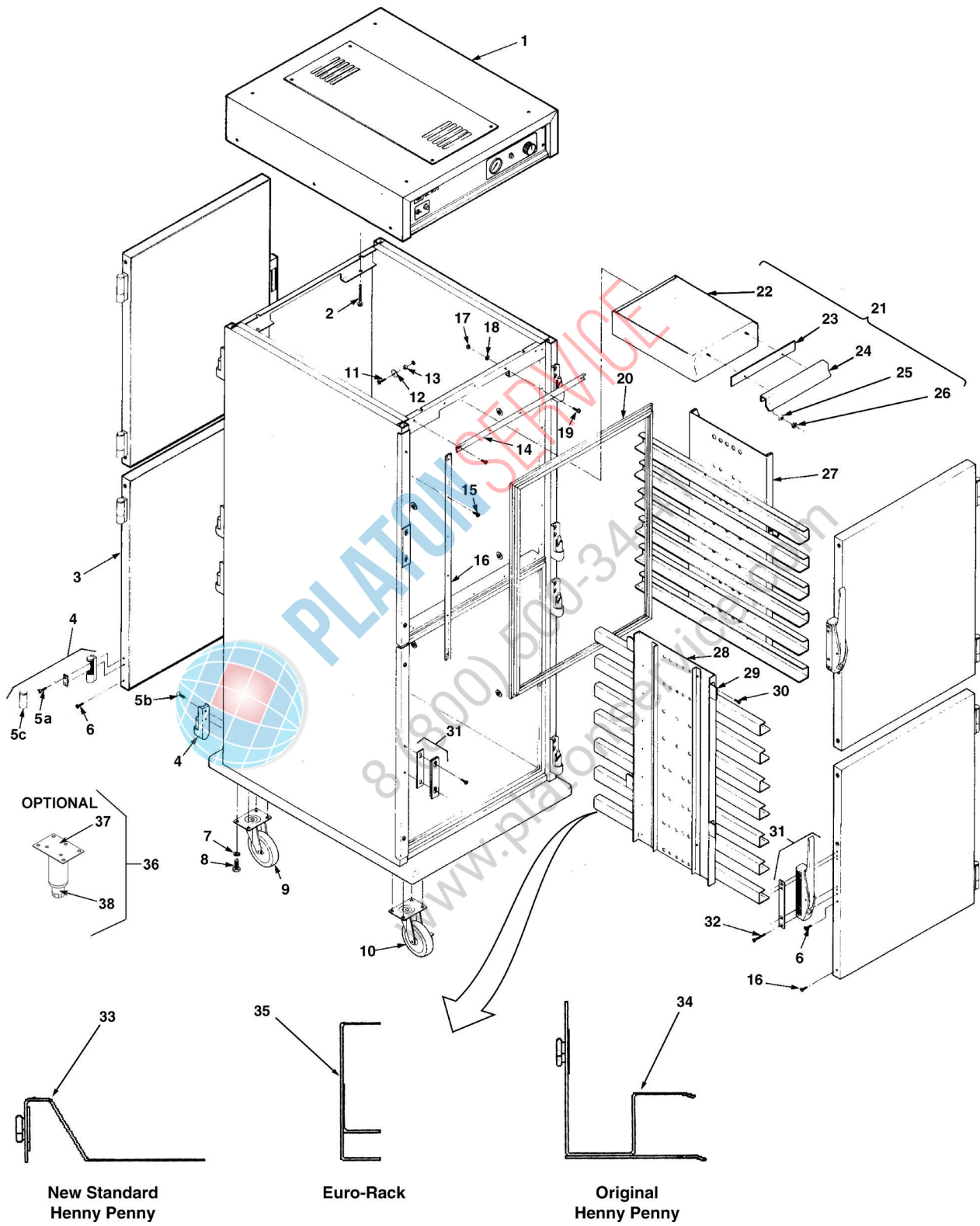

Figure 3-2. Cabinet Assembly - UL & CE Approved

UL & CE Approved - HHC-900/902/903/904/906/908

<u>Figure No.</u> <u>& Item No.</u>	<u>Part No.</u>	<u>Description</u>	<u>Quantity</u>
3-2		Cabinet Assembly - UL & CE Approved	
1	Contact HP	Control Module 120V, 2,000W.....	1
1	Contact HP	Control Module 120V, 1,500W, HHC-903	1
1	Contact HP	Control Module 120V, 2,000W, HHC-906, HHC-908.....	1
2	SC01-170	Screw #10-32 x 2-1/2 PH PHD.....	4
3	28816	Right Hand Top Door Assembly.....	1
3	28817	Right Hand Bottom Door Assembly.....	1
3	28818	Left Hand Top Door Assembly.....	1
3	28819	Left Hand Bottom Door Assembly.....	1
3	27033	Right Door Assembly, HHC-903.....	1
3	27034	Left Door Assembly, HHC-903.....	1
3	28158	Right Hand Top Door Assembly, HHC-906.....	1
3	85644	Left Hand Top Door Assembly, HHC-906.....	1
3	85645	Right Hand Bottom Door Assembly, HHC-906.....	1
3	85646	Left Hand Bottom Door Assembly, HHC-906.....	1
3	28166	Right Hand Door Assembly, HHC-908.....	1
3	28168	Left Hand Door Assembly, HHC-908.....	1
4	14271	Kit - HHC-900 Hinge.....	8
5a	SC01-086	Screw #10-32 x 1 PH TH S.....	16
5b	SC01-225	Screw #10-32 x 3/4 PH TH S.....	24
5c	27146	Cover - Hinge Pin - Chrome.....	8
6	SC01-074	Screw #10-32 x 1/2 PH TH.....	16
7a	LW01-002	Lockwasher Split 1/4".....	8
7b*	WA01-013	Flat Washer 1/4".....	8
8a	SC01-039	Screw 1/4-20 x 1 Hex Head.....	8
8b	SC01-193	Screw 1/4-20 x 3/4" Hex Head.....	8
9a	27155	Caster 5" (See item 52).....	2
9b	40948	Caster-4"; Rigid (See item 51).....	2
9c	58139	Caster-3" Dia.; 4" Height; Rigid (See item 50).....	2
9d	18645	Caster 2-1/2".....	2
9e	68804	Caster 5" - CE.....	2
9f	28170	Caster 5" Non-Swivel HHC-906, HHC-908.....	2
9g	19004	Caster 2".....	4
9h	78671	Caster 1.5" - Swivel.....	4
10a	27154	Caster 5" W/Brake (See item 52).....	2
10b	40947	Caster-4"; Swivel W/Brake (See item 51).....	2
10c	58138	Caster-3" Dia.; 4" Height; Swivel W/Brake (See item 50).....	2
10d	18646	Caster 3" W/Brake.....	2
10e	68803	Caster 5" W/Brake - CE.....	2
11	SC01-075	Screw #10-32 x 3/. PHT TH.....	12
12	25695	Washer.....	12

√ recommended parts/*not shown

UL & CE Approved - HHC-900/902/903/904/906/908

<u>Item No.</u>	<u>Part No.</u>	<u>Description</u>	<u>Quantity</u>
13	25644	Spacer.....	12
14	25687	Retainer, HHC-900; HHC-903	8 & 4
14	28117	Retainer, HHC-906; HHC-908	8 & 4
15	SC02-041	Screw #8-18 x 7/16 PH IND XTRNL TORX.....	24
16	25689	Retainer, HHC-900	8
16	25690	Retainer, HHC-903	4
17	NS01-008	Nut #8-32 Hex S	10
18	LW02-006	Lockwasher Internal #8 S	10
19	SC01 -053	Screw #8-32 x 1/2 PH RHD.....	10
B 20	25643	Gasket Door	4
B 20	25793	Gasket - Door, HHC-903	4
B 20	28147	Gasket - Door, HHC-906	2
B 20	28143	Gasket - Door, HHC-908	1
21	71478	Water Box Assembly with Handle - HHC-903 - Flip Doors	1
21	25879	Water Box Assembly with Handle.....	1
22	25707	Water Box and Stud Assembly	1
22	70381	Water Box and Stud Assembly - HHC-903 - Flip Doors....	1
23	25646	Wiper.....	1
24	25685	Pull.....	1
25	LW02-005	Lockwasher Internal #10	2
26	NS03-030	Nut Acorn #10-32	2
27	27895	Air Duct Assembly - Upper	2
27	42964	Air Duct Assembly - Upper - HHC-900K (SIB)	2
27	52345	Air Duct -Upper-KFC-Int'l-CDT-15 Tray	2
27	25957	Air Duct Assembly - HHC-903.....	2
27	70387	Air Duct Assembly - HHC-903 - Flip Doors.....	2
27	70032	Air Duct Assembly - HHC-903 - Pollo Campero	2
27	34928	Air Duct Assembly- Upper - Boston Mkt.....	2
27	55181	Air Duct Assembly- Upper- Churches	2
27	55087	Air Duct Assembly-Upper-Wendy's #10	2
27	28129	Air Duct-Upper ONLY-NO SLIDES HHC-906 (uses 28133 slides)	2
27	34519	Air Duct-Upper ONLY-NO SLIDES-Knotts Berry-HC-906 (uses 34536 slides)	2
28	55088	Air Duct Assembly-Lower-Wendy's #10.....	2
28	55084	Air Duct Assembly-Wendy's-903 Plast.	2
28	27811	Air Duct Assembly - Lower.....	2
28	55187	Air Duct Assembly- Lower-Churches.....	2
28	34929	Air Duct Assembly-Lower-Boston Mkt.....	2
28	52346	Air Duct-Lower-KFC-Int'l-CDT-15 Tray.....	2
28	42965	Air Duct Assembly - Lower HHC-900K(SIB)	2
28	28130	Air Duct ONLY-NO SLIDES - Lower HHC-906 (uses 28133 slides)	2
28	34517	Air Duct -Lower ONLY-NO SLIDES-Knotts Berry-HC-906 (uses 34536 slides)	2
28	28128	Air Duct ONLY-NO SLIDES - HHC-908 (uses 28133 slides).	2
28	34553	Air Duct ONLY-NO SLIDES-Knotts Berry-HC-908 (uses 34536 slides)	2

√ recommended parts

UL & CE Approved - HHC-900/902/903/904/906/908

<u>Item No.</u>	<u>Part No.</u>	<u>Description</u>	<u>Quantity</u>
29	25696	Hanger.....	16
30	SC02-023	Screw #8-B x 3/8 PH THD S.....	8
31	14272	Latch/Screw Kit.....	4
32	SC01-186	Screw #10-32 x 1-3/4 PH.....	16
33	34536	Slides ONLY - HHC-906, HHC-908.....	22 & 8
34	28133	Slides ONLY, HHC-906, HHC-908.....	22 & 8
35	34544	Air Duct Assembly Complete - HHC-908,.....	2
35	34545	Air Duct Assembly Complete - Lower - HHC-906.....	2
35	34550	Air Duct Assembly Complete - Upper - HHC-906.....	2
36	14647	Kit - Leg Adjustable - 4 inch (Set of 4 legs).....	1
36	68946	Legs - Adjustable - 4 inch.....	4
37	68937	Weld Assy - Mtg. Plate & Leg - 4 inch.....	4
38	26120	Foot - Adjustable.....	4
39	27149	Stop - Door.....	4
39	34949	Door Stop - Boston Mkt.....	4
40*	27146	Chrome Hinge Cover.....	1
41*	27912	Handle, HHC-906, HHC-908.....	1
42*	27939	Brkt. Handle, HHC-906, HHC-908.....	2
43*	58116	Hinge Plate (Tap Bar) HHC-900.....	4
44*	58274	Hinge Plate (Tap Bar) HHC-903.....	4
45*	03182	Worktop - HHC-903.....	1
46*	56179	Worktop - HHC-908.....	1
47*	14853	Kit - 903 Undercounter CVSRN.....	1
48*	58047	Insulation - Side.....	2
49*	03559	Accessory - Storage Bin.....	1
50*	86832	3" Caster Set (Includes items 7a, 7b, 8b, 9b, & 10b).....	1
51*	86833	4" Caster Set (Includes items 7a, 7b, 8b, 9c, & 10c).....	1
52*	86850	5" Caster Set (Includes items 7a, 8a, 9a, & 10a).....	1
Glass Doors Only			
3	54353	Glass Door Assembly - 1/3 size(LH).....	1
3	54352	Glass Door Assembly - 1/3 size(RH).....	1
--	30517*	Nut - Glass Retainer.....	4
3	59257	Glass Door Assy.-Left, Top.....	1
3	59258	Glass Door Assy.-Left, Bottom.....	1
3	59260	Glass Door Assy.-Right, Top.....	1
3	59261	Glass Door Assy.-Right, Bottom.....	1
3	76480	Glass Door Assy. - 1/2 size (McD's).....	1
Church's HHC-903			
3	54353	Glass Door Assembly - 1/3 size (LH).....	1
3	54352	Glass Door Assembly - 1/3 size (RH).....	1

* not shown

UL & CE Approved - HHC-900/902/903/904/906/908

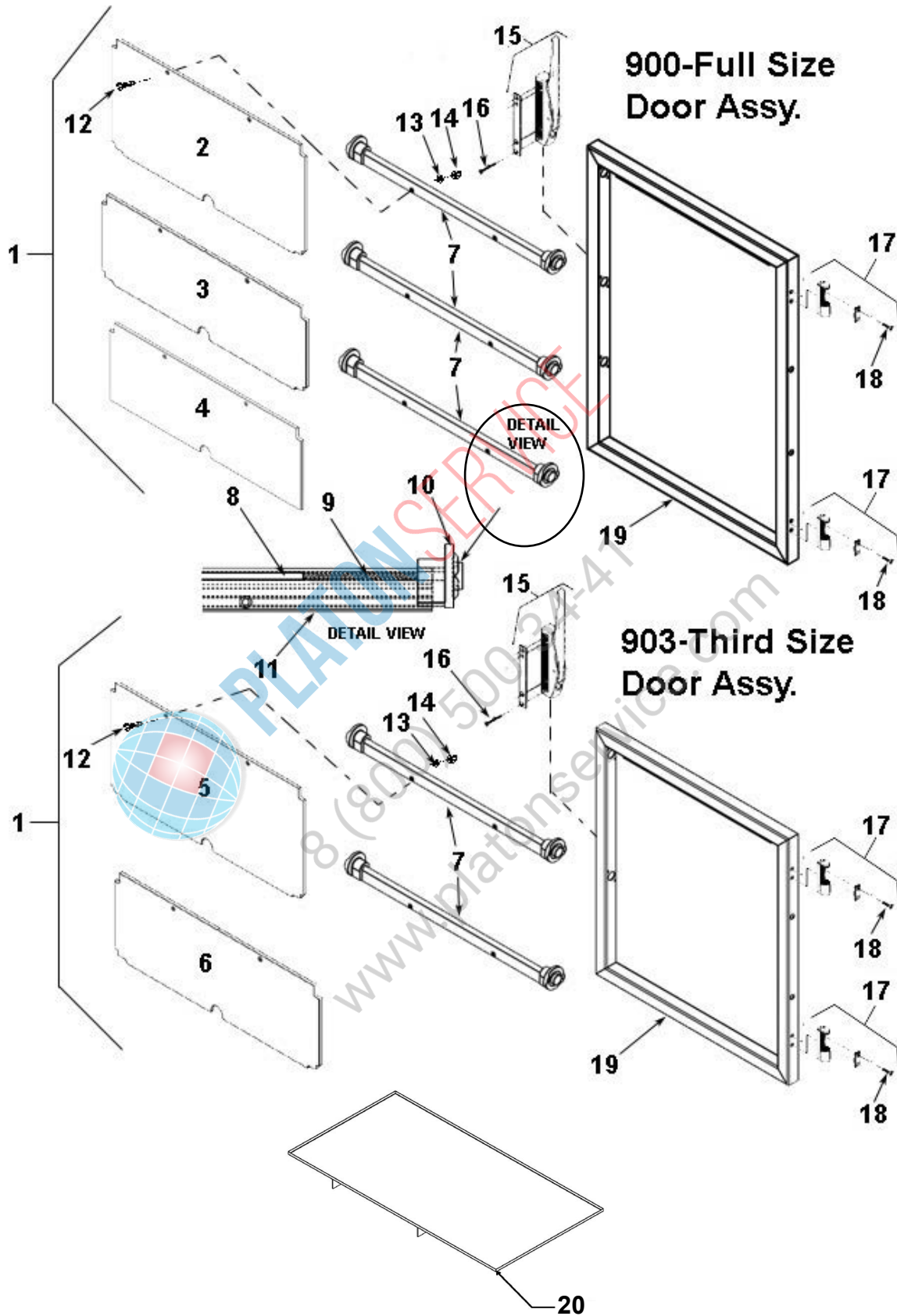

Figure 3-3. Flip-Up Door Assemblies (HHC-903 - SN: DA0511040 & Above)

UL & CE Approved - HHC-900/902/903/904/906/908

NOTICE

- HHC-903's (1/3-size) with SN: DA0511039 & below, **SN required.**
- HHC-900 (full-size) with SN: DA0511039 & below, **no parts available.**
Complete door assembly must be ordered.

<u>Figure No.</u> <u>& Item No.</u>	<u>Part No.</u>	<u>Description</u>	<u>Oty per Door</u>	
			<u>900</u>	<u>903</u>
3-3		Flip-Up Door Assemblies		
1	71309	Assy - Door - Flip - RH - Full Size	1	-
1	71403	Assy - Door - Flip - LH - Full Size	1	-
1	71466	Assy - Door - Flip - RH - 1/3 Size (DA0511040 & Above).....	-	1
1	71467	Assy - Door - Flip - LH - 1/3 Size (DA0511040 & Above).....	-	1
2	75544-004	Panel - Flip Door - 9.562 HGT.....	1	-
3	75544-003	Panel - Flip Door - 6.860 HGT.....	1	-
4	75544-005	Panel - Flip Door - 6.735 HGT.....	1	-
5	75544-001	Panel - Upper Flip Door - 1/3 Size.....	-	1
6	75544-002	Panel - Lower Flip Door - 8.108 HGT	-	1
7	71308	Assy - Hinge - Panel - Door - Flip.....	3	2
8	71067	Rod - Flip Door	3	2
9	71316	Spring - Flip Door	3	2
10	70768	Cam - Flip Door - RH.....	3	2
10	70769	Cam - Flip Door - LH.....	3	2
11	73320	Extrusion - Flip Door	3	2
12	SC01-032	Screw - #8-32 x 5/8 PH 100 FHD SS.....	6	4
13	LW02-006	Lockwasher - Internal - #8 S	6	4
14	NS03-024	Nut - #8-32 Low Crown Acorn - B P	6	4
15	14272	Kit - HC-900 Door Handle	1	1
16	SC01-186	Screw - #10-32 x 1-3/4 PH FHD SS.....	4	4
17	14271	Kit - HC-900 Door Hinge.....	2	2
18	SC01-086	Screw - #8-32 x 1 PH FHD S.....	4	4
19	71310	Weld Assy - Flip Door Frame - RH - Full Size	1	-
19	71404	Weld Assy - Flip Door Frame - LH - Full Size.....	1	-
19	71056	Weld Assy - Flip Door Frame - RH - 1/3 Size.....	-	1
19	71057	Weld Assy - Flip Door Frame - LH - 1/3 Size.....	-	1
20	03557	Accessory - Flip Door Tray	-	1

Non-UL & Non-CE Approved - HHC-900 EM, HHC-900 CDT, & HC-15

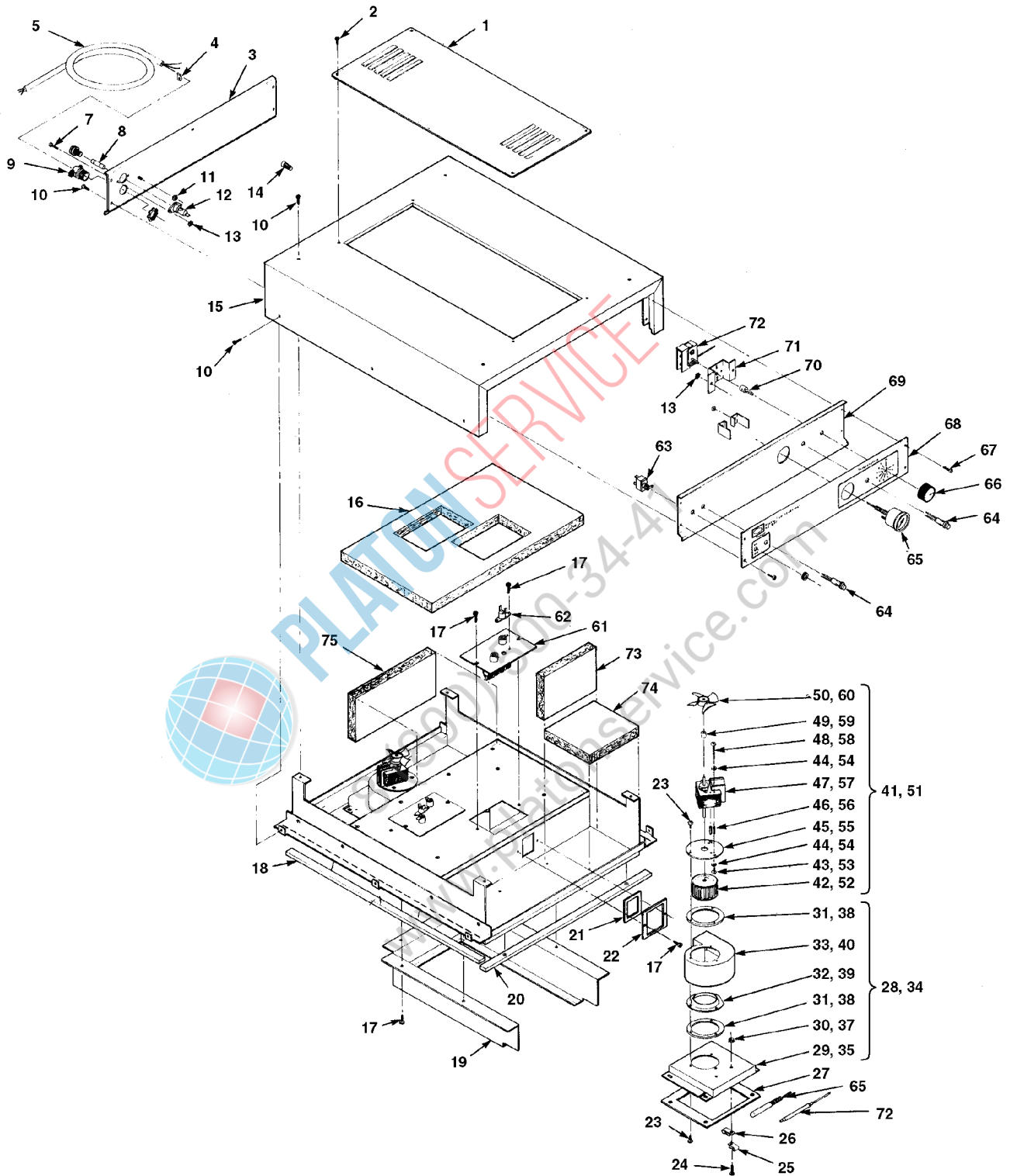

Figure 3-4. Control Module Assembly - Non-UL, Non-CE

Non-UL & Non-CE Approved - HHC-900 EM, HHC-900 CDT, & HC-15

<u>Figure No.</u> <u>& Item No.</u>	<u>Part No.</u>	<u>Description</u>	<u>Quantity</u>
3-4		Control Module Assembly - Non-UL, Non-CE	
1	72312	Panel - Access Louvers (HHC-900EM & HC-15).....	1
1	80890	Panel -Access Louvers (HHC-900CDT)	1
2	SC02-023	Screw #8-32 x 1/2 PH RHD.....	4
3	28029	Panel - Rear (208/240V) S/A (HHC-900EM).....	1
3	72404	Panel - Rear (120V) S/A (HHC-900CDT).....	1
3	72317	Panel Rear S/A (HC-15).....	1
4	EC04-004	Terminal Flag #10-10-12 Ga.....	1
5	31584	Power Cord Assy (HHC-900CDT).....	1
5	71384	Power Cord Assy-240V (HHC-900EM & HC-15).....	1
5	72532	ASSY-PWR CORD 120/30A TWIST LK	1
7	SC01-010	Screw #6-32 x 112 pH PHD	2
A 8	EF02-007	Fuse 15 Amp	1
9	49778	Connector - Cable 3/4	1
10	SC02-023	Screw 48-B x 3/8 pH THD	15
11	NS02-001	Nut #10-32 Hex Keps	1
A 12	EF02-006	Fuse Holder	1
13	NS02 005	Nut #6-32 Hex Keps	2
14	EC01-010	Wire Nut 12-18 Ga.....	2
15	72305	Top - Enclosure (HHC-900EM & HC-15).....	1
15	84607	Top - Enclosure (HHC-900CDT).....	1
16	26225	Insulation - Cover	1
17	SC02-041	Screw #8-18 x 7/16 PH IND XTRNL TORX.....	18
18	25620	Seal.....	2
19	25670	Cradle.....	1
20	25624	Seal.....	2
21	25619	Gasket - Blower Outlet	2
22	25618	Gasket Retainer	2
23	SC02-041	Screw #8-18 x 7/16 PH IND XTRNL TORX.....	2
24	SC01-074	Screw #10-32 x 3/4 Hex HD.....	2
25	EF02-031	Clamp 1/4 x 3/8" (HC-15)	2
26	EF02-003	Wire Tie.....	4
27	25627	Gasket	2
28	72915	Blower Box Assembly (HHC-900 EM & CDT).....	2
29	72914	Box, Blower (HHC-900 EM & CDT)	1
30	NS02-001	Nut.....	2
31	25698	Gasket, Blower Plate (HHC-900 EM & CDT).....	1
32	25622	Flange, Inlet (HHC-900 EM & CDT).....	1
33	25623	Housing, Blower (HHC-900 EM & CDT).....	1
34	87097	Blower Box Assembly (HC-15).....	2
35	72914	Rear Box, Blower (HC-15).....	1
37	NS02-001	Nut.....	2
38	25698	Gasket, Blower Plate (HC-15).....	2
39	25622	Flange, Inlet (HC-15).....	1
40	25623	Housing, Blower (HC-15).....	1

√ recommended parts

Non-UL & Non-CE Approved - HHC-900 EM, HHC-900 CDT, & HC-15

<u>Item No.</u>	<u>Part No.</u>	<u>Description</u>	<u>Quantity</u>
51	14249	Blower Motor Assembly (240V)	2
52	52240	Wheel, Blower, Int'l.....	1
53	SC01-023	Screw.....	4
54	LW02-010	Lockwasher	4
55	37157	Plate, Blower.....	1
56	81606	Spacer, Motor.....	4
A 57	25752	Motor (240V).....	1
58	SC01-091	Screw.....	4
59	25768	Spacer, Fan.....	1
A 60	25706	Fan, Cooling.....	1
A 61	51279	Heater 120V/1000W	2
A 62	18201	High Limit Thermostat.....	2
A 63	95230	Power Switch (HHC-900EM & HC-15).....	1
A 63	72277	Black Rocker Switch (HHC-900CDT).....	1
B 64	16624	Indicator Light - Red (HHC-900EM & HC-15)	2
A 65	14250	Thermometer (HHC-900 EM & HC-15)	1
66	25863	Knob - Thermostat	1
67	SC02-030	Screw #8-B x 3/8 PH THD Black Oxide.....	4
68	44204	Decal-Control (HHC-900EM).....	1
68	85249	Decal-Control (HHC-900CDT).....	1
68	87065	Decal-Control (HC-15)	1
69	72440	Panel Control S/A (HHC-900EM & HC-15).....	1
69	81307	Panel Control S/A (HHC-900CDT).....	1
71	25241	Bracket Thermostat Mount	1
A 72	14209	Thermostat w/clips.....	1
73	25734	Insulation 5 x 7 x 1.....	2
74	25733	Insulation 6 x 6 1/2 x 1	4
75	25735	Insulation 5 x 10 1/2 x 1	2
A 80*	83758	Control & Display PCB Assy - 13 Timer (HHC-900CDT)	1
A 83*	ME90-009	Relay 240V coil, 30A (HHC-900CDT)	1
A 84*	92406	Transformer 240V (HHC-900CDT)	1
103*	27870	Insulator, Fan Motor	1

√ recommended parts/* not shown

Non-UL & Non-CE Approved - HHC-900 EM, HHC-900 CDT, & HC-15

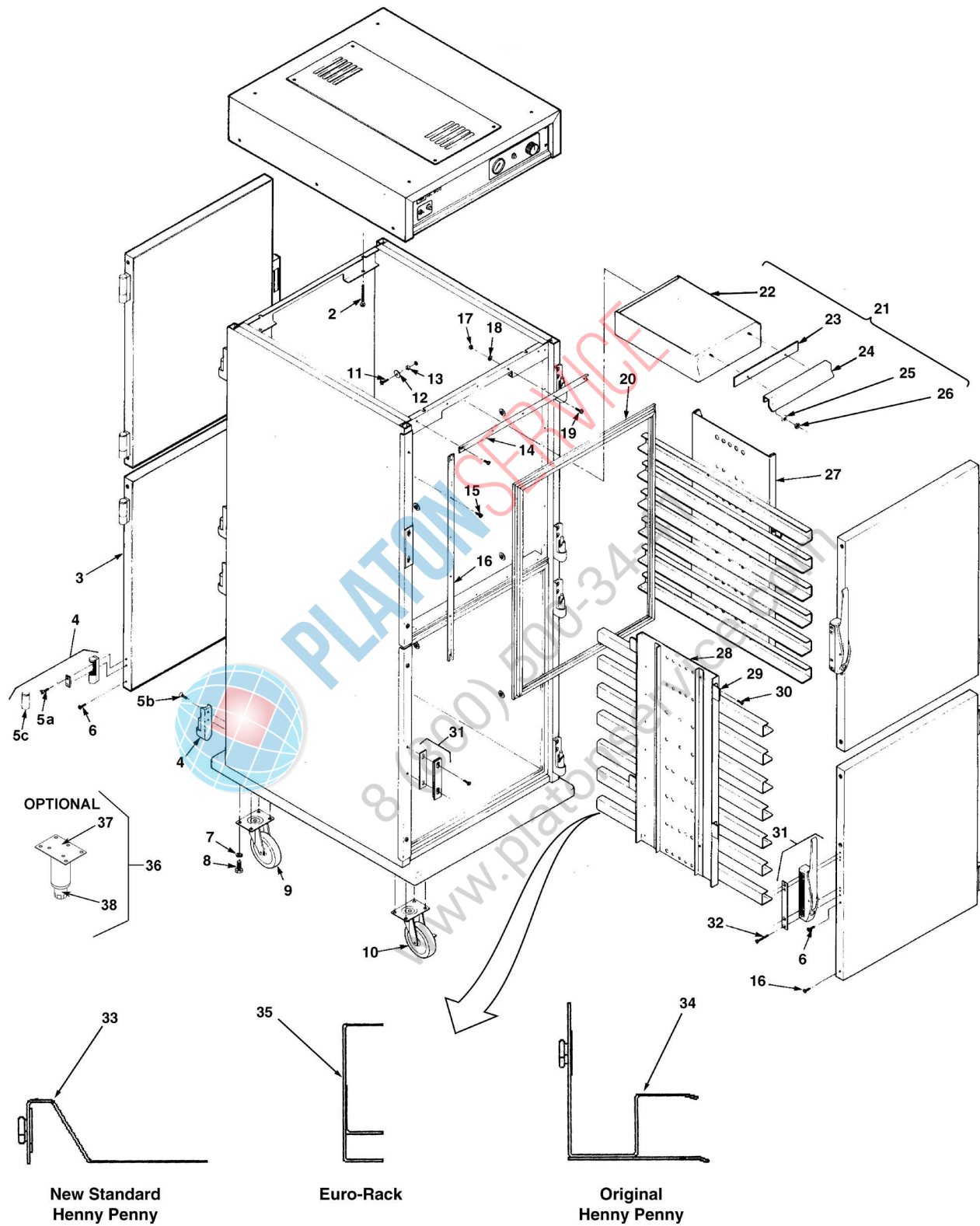

Figure 3-5. Cabinet Assembly - Non-UL, Non-CE

Non-UL & Non-CE Approved - HHC-900 EM, HHC-900 CDT, & HC-15

Figure No.

Figure No. & Item No.	Part No.	Description	Quantity
3-5		Cabinet Assembly - Non-UL, Non-CE	
2	SC01-170	Screw #10-32 x 2-1/2 PH PHD.....	4
2*	LW02-004	Lockwasher.....	4
2*	WA01-022	Flat Washer.....	2
2*	37151	Spacer (HHC-900EM & HC-15).....	2
3	59257	Glass Door Assy.-Left, Top.....	1
3	59258	Glass Door Assy.-Left, Bottom.....	1
3	59260	Glass Door Assy.-Right, Top.....	1
3	59261	Glass Door Assy.-Right, Bottom.....	1
4	14271	Kit - Hinge.....	8
5a	SC01-086	Screw #10-32 x 1 PH TH S.....	16
5b	SC01-225	Screw #10-32 x 3/4 PH TH S.....	24
5c	27146	Cover - Hinge Pin - Chrome.....	8
6	SC01-074	Screw #10-32 x 1/2 PH TH.....	16
7	LW01-002	Lockwasher Split 1/4".....	8
8	SC01-104	Screw 1/4-20 x 1-1/2" Hex Head.....	8
9	72365	Caster 5".....	2
10	72364	Caster 5" W/Brake.....	2
11	SC01-075	Screw #10-32 x 3/4 PHT TH.....	12
12	25695	Washer.....	12
13	25644	Spacer.....	12
14	25687	Retainer.....	8 & 4
15	SC02-041	Screw #8-18 x 7/16 PH IND XTRNL TORX.....	24
16	25689	Retainer.....	8
17	NS01-008	Nut #8-32 Hex S.....	10
18	LW02-006	Lockwasher Internal #8 S.....	10
19	27944	Cap Screw #8.....	10
B 20	25643	Gasket Door.....	4
21	72405	Water Box Assembly with Handle.....	1
22	72406	Water Box and Stud Assembly.....	1
23	25646	Wiper.....	1
24	25685	Pull.....	1
25	LW02-005	Lockwasher Internal #10.....	2
26	NS03-030	Nut Acorn #10-32.....	2
27	27895	Air Duct Assembly - Upper (HHC-900CDT).....	2
27	52345	Air Duct -Upper-15 Tray (HHC-900EM & HC-15).....	2
28	27811	Air Duct Assembly - Lower (HHC-900CDT).....	2
28	52346	Air Duct-Lower-15 Tray (HHC-900EM & HC-15).....	2
31	14272	Latch/Screw Kit.....	4
32	SC01-186	Screw #10-32 x 1-3/4 PH.....	16
39	27149	Stop - Door (HHC-900EM & HHC-900CDT).....	4
48*	58047	Insulation - Side.....	1
53*	72366	Plate - Caster (HHC-900EM).....	4

√ recommended parts / * not shown



PLATONSERVICE

8 (800) 500-34-47

www.platonservice.com